

ETH-712-D:

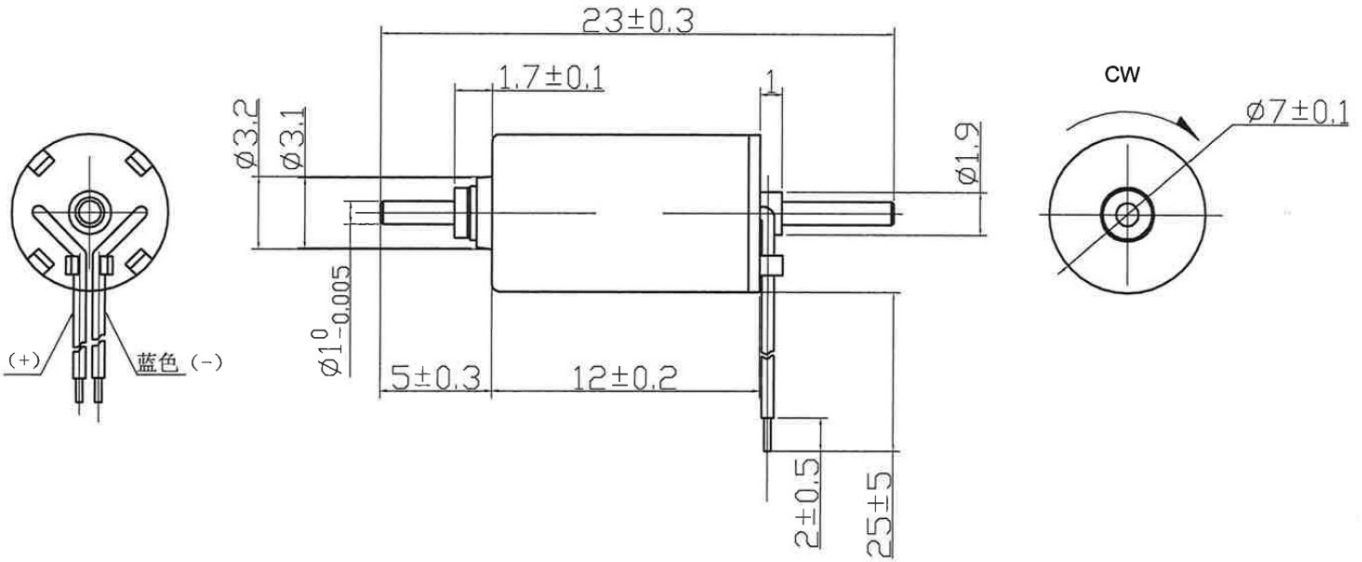

ETH-816-D:

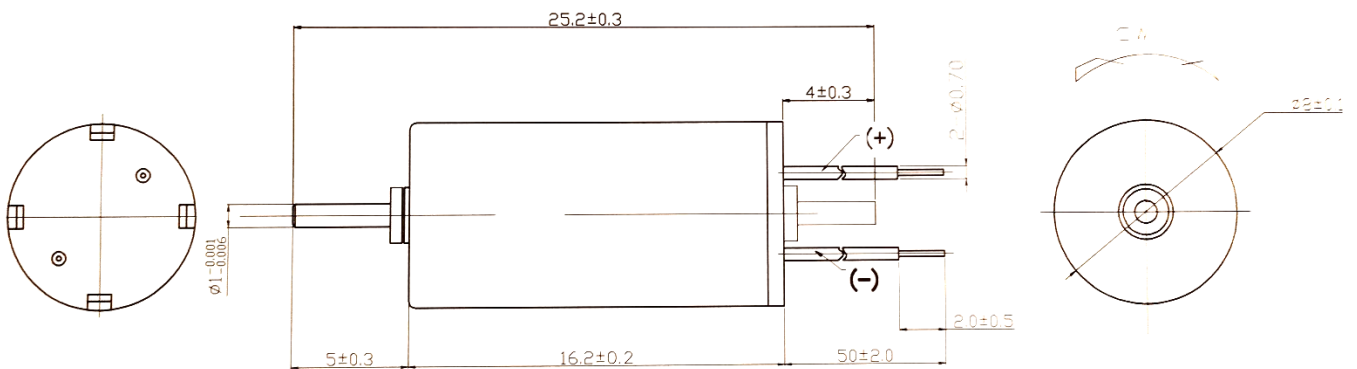

ETH-MGL:

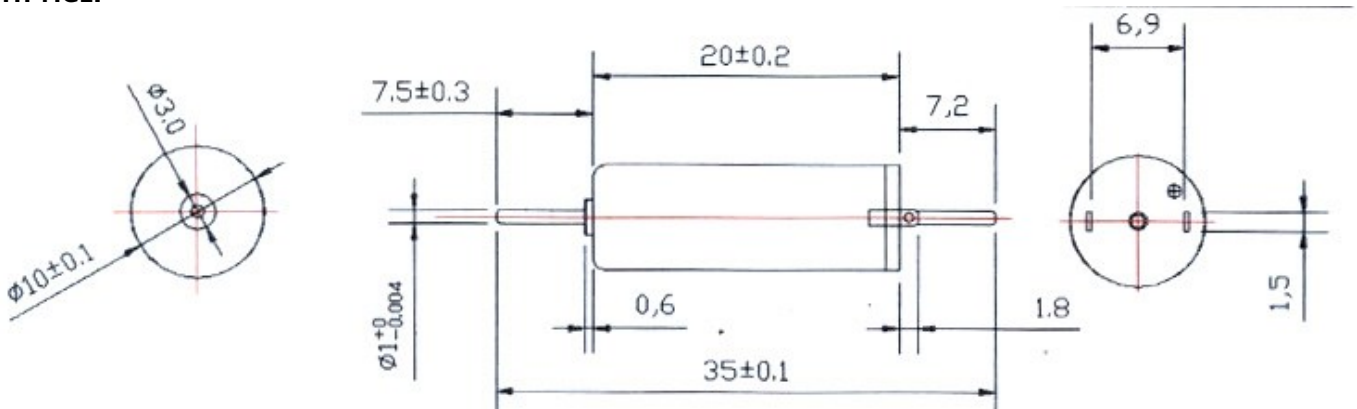

ETH-MAB:

DIRECTION OF ROTATION

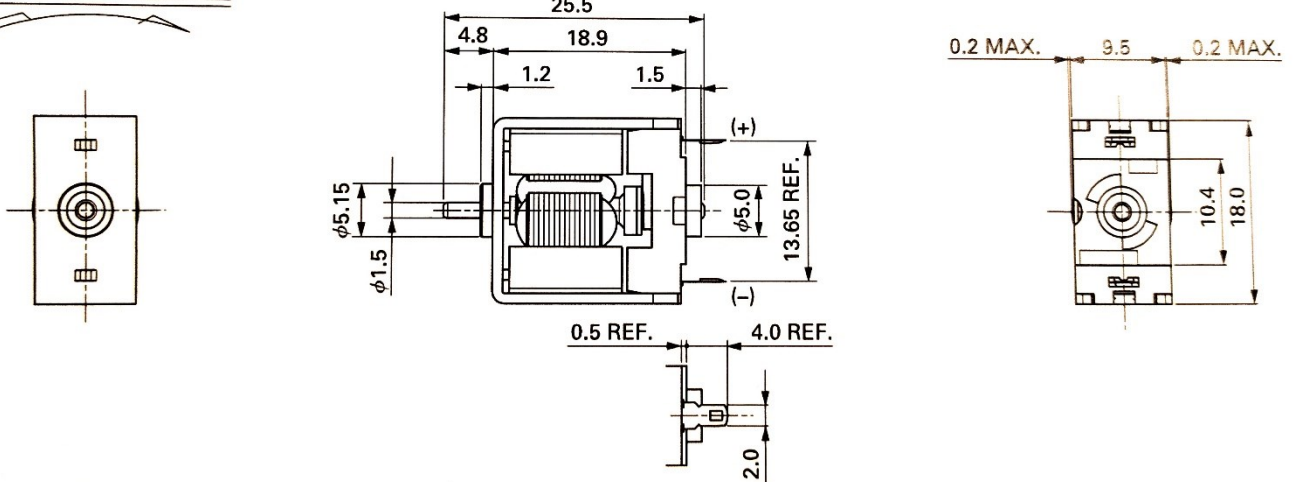

Spezifikationen der Motoren / Specifications for the motors

Artikel	Typ	Maße [mm]	Achsen	Achse [mm]	Achse vorne	Achse hinten	Achse Ø	Volt	ohne Belastung/ no load		Max. Effizient/ max. efficiency				Motor-Stillstand/ Stall	
									speed	current	speed	current	torque	output	torque	current
		Size [mm]	Shafts	Shaft [mm]	front shaft	back shaft	shaft Ø	volt	speed	current	speed	current	torque	output	torque	current
ETH-712-D	712D Coreless, Dual Shaft	Ø 7,0 L = 12,0	2	23,0	4,0	6	1,0	12	15000	40 mA	14300	100 mA	3 g	W	12,8 g	220 mA
ETH-816-D	816D Coreless, Dual Shaft	Ø 8,0 L = 16,0	2	34,5	10,0	7,5	1,0	12	12300	50 mA	11000	30 mA	3 g	W	14,5 g	150 mA
ETH-MGL	1020-35 Coreless, Dual Shaft	Ø 10,1 L = 20,0	2	35,0	7,5	7,5	1,0	12	21000	19 mA	18667	130 mA	5 g	0,96 W	45,0 g	970 mA
ETH-MAB	Sh-030SA Three Pole, Dual Shaft	Ø 9,5 L = 18,9	2	28,5	3,6	2,9	1,5	12	22300	80 mA	16730	240 mA	7,2 g	1,24 W	29,0 g	720 mA
ETH-MZRB	Sh-030SA Three Pole, Single Shaft	Ø 9,5 L = 18,9	1	28,5	6,1	0,4	1,5	12	22300	80 mA	16730	240 mA	7,2 g	1,24 W	29,0 g	720 mA

ETH-MHA:

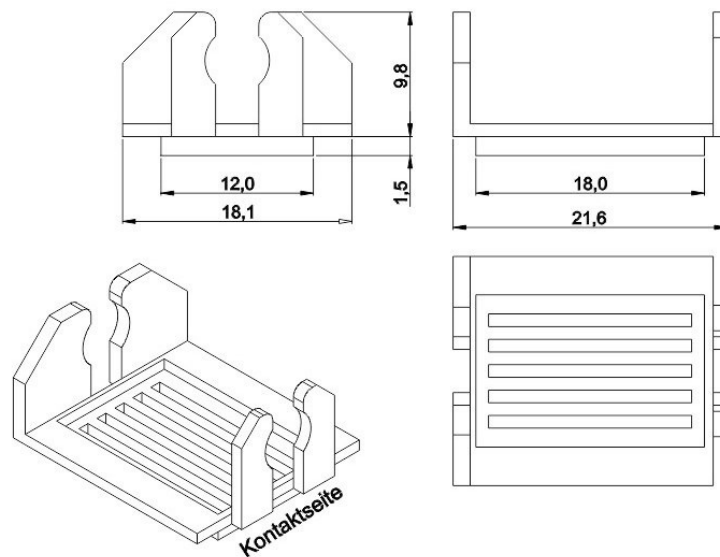

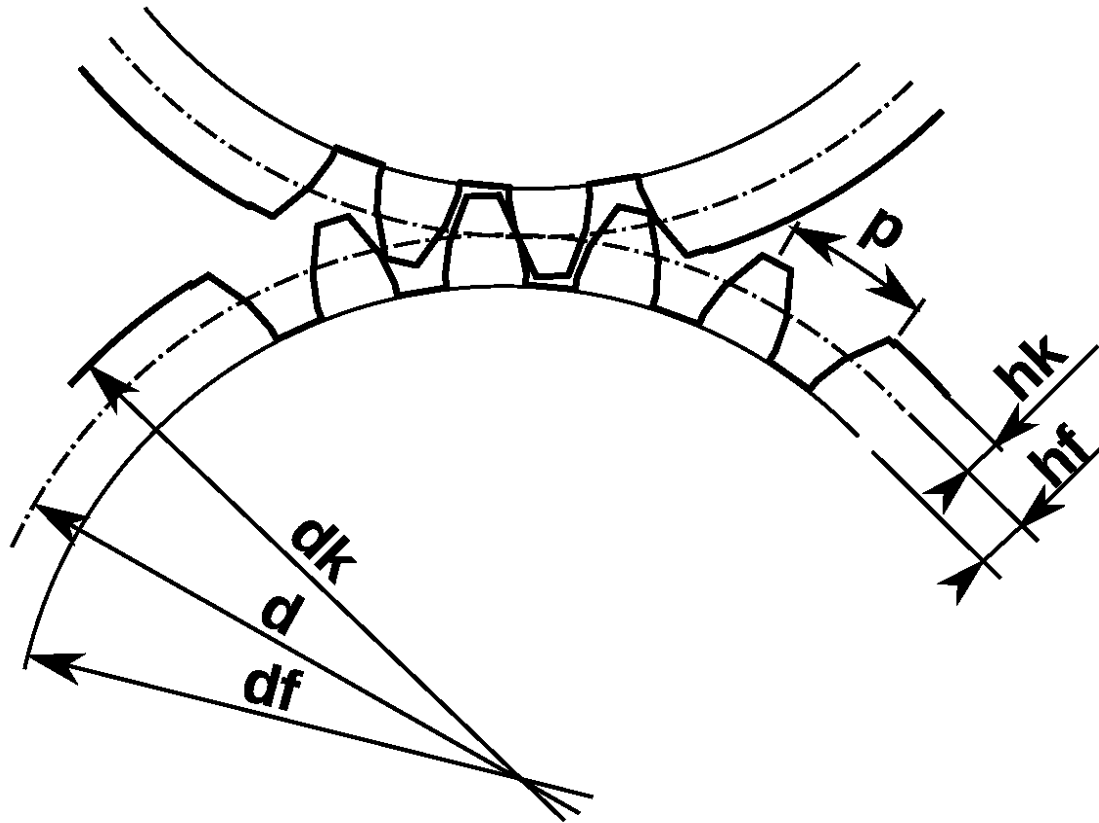

Untersetzung der Antriebsdrehgestell / Specifications for bogies with gear box									
Achs-stand	Interne Bezeichn.	Unter-setzung	ZR1	ZR1	ZR1	ZR1	ZR1	ZR1	ZR1
19,7	GT4	1:20	20R	14L	16R	14L	20R		
21 mm	K-5000	1:22	22R „S“	16L	16R	16L	22R „S“		
23 mm	SSB	1:22	22R „S“	16L	22R	16L	22R „S“		
24 mm	S-Bahn B	1:22	22R „S“	19L	19R	19L	22R „S“		
25,3 mm	HTP	1:22	22R „S“	22L „S“	17R „S“	22L „S“	22R „S“		
21,7 mm	Stehender	1:17	17R	16L	20R „S“	19L	20R „S“	19L	20R „S“

ZR1 ist das erste ZR nach der Schnecke

Markierung zeigt ZR auf Achse an

Zahnradliste Modul 03

Nummer	R / L / G	Bohrung	Breite ZR	m. Schulter	DM (dk)	Nr. alt
12GOA	G	1,48	1,50		4,20	
12GOA	G	0,95	2,20		4,20	
13GOA	G	1,48	2,20		4,50	24
13LSA	L	1,48	2,20	3,30	4,50	1
13LOA	L	1,48	2,20		4,50	
13LOF	L	1,54	2,20		4,50	2
13ROF	R	1,54	2,20		4,50	
14LOF	L	1,54	2,20		4,80	27
16LOA	L	1,48	2,20		5,40	
16LOF	L	1,54	2,20		5,40	6
16RSA	R	1,48	2,20	3,30	5,40	
16RSF	R	1,54	2,20	3,30	5,40	7
16ROF	R	1,54	2,20		5,40	5
17GOA	G	1,48	2,20		5,70	25
17RSA	R	1,48	2,20	3,30	5,70	8
17RSF	R	1,54	2,20	3,30	5,70	9
19 ROF	R	1,54	2,20		6,30	11
19LSF	L	1,54	2,20	3,30	6,30	
19LOF	L	1,54	2,20		6,30	12
19ROA	R	1,48	2,20		6,30	10
20RSA	R	1,48	2,20	3,30	6,60	15
20RSF	R	1,54	2,20	3,30	6,60	
20ROA	R	1,48	2,20		6,60	14
20ROF	R	1,54	2,20		6,60	13
21GOA	G	1,48	1,10		6,90	28
21ROF	R	1,54	1,20		6,90	
22LSA	L	1,48	2,20	3,30	7,20	16
22LOA	L	1,48	2,20		7,20	17
22RSA	R	1,48	2,20	3,30	7,20	18
22RSF	R	1,54	2,20		7,20	
22ROF	R	1,54	2,20		7,20	19
24LSA	L	1,48	2,20	3,30	7,80	22
24LOA	L	1,48	2,20		7,80	
24RSA	R	1,48	2,20	3,30	7,80	21
24RSF	R	1,54	2,20	3,30	7,80	23
24ROF	R	1,54	2,20		7,80	
26GOA	G	1,48	2,20		8,40	26
23G16GF	G/G	1,54	2,20		7,5/5,4	
26R14GA	R/G	1,48	2,80		8,4/4,8	

////	Rechts	Schneckenzahnrad
\\\\\\	Links	Getriebezahnrad
IIIII	Gerade	g. verzahnte Getriebe

alle Maße: [mm]

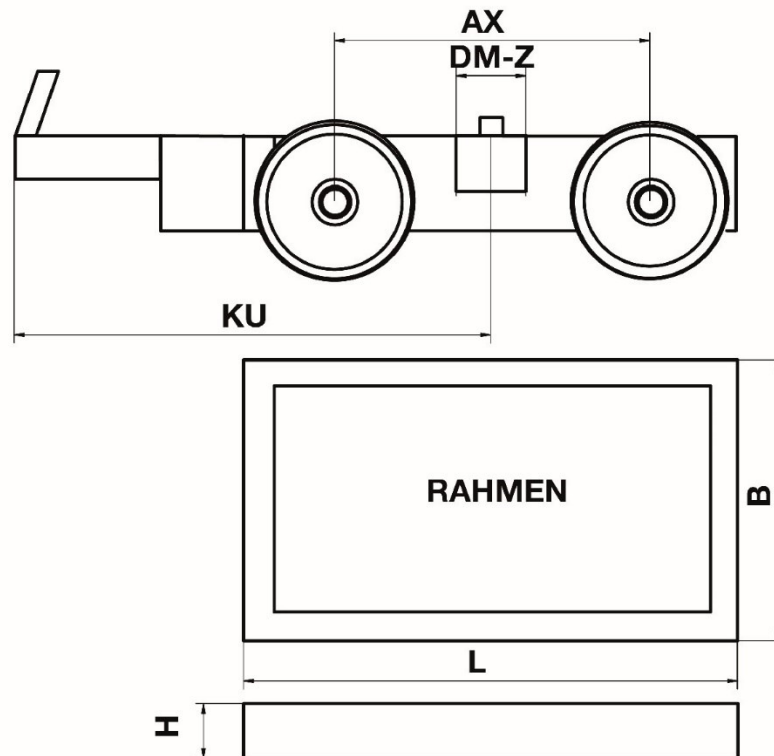

H0e Drehgestelle / H0e Bogies [mm]

		EHE1908	EHE1032	EHE1033
AX	Achsabstand	16,4	15,8	16,3
DM-Z	Durchmesser Zapfenloch	3,5	3,5	3,9
KU	Abstand Kupplung Mittelpunkt Zapfen	25,5	25,8	28,9
L	Kasten-Länge	29,8	29,9	26,4
B	Kasten-Breite	14,6	14,8	14,6
H	Kasten-Höhe	3,1	2,5	1,6
H ges	Kasten + Blenden	6,3	5,4	5,3

ETH-ADG-197-xx – Antriebsdrehgestell 19,7 mm:

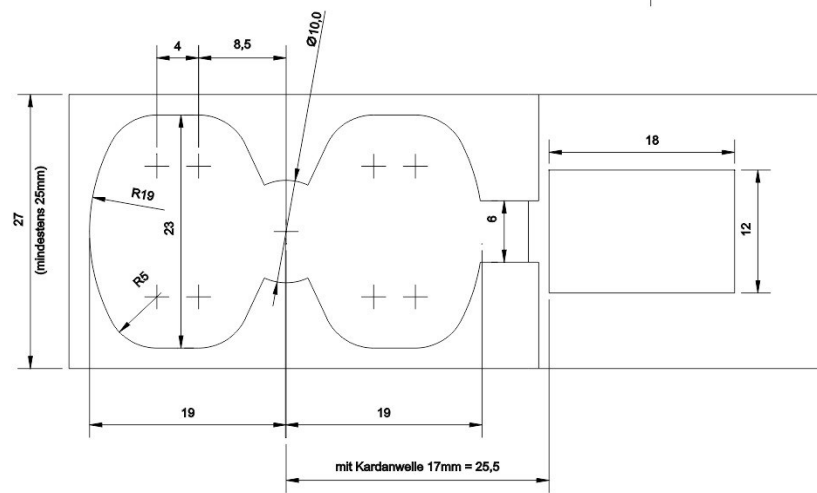
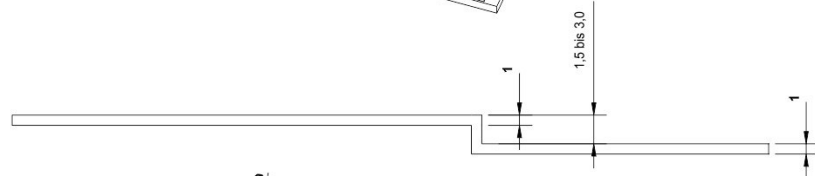
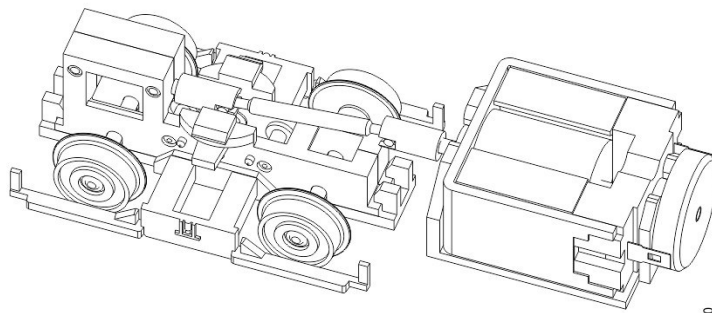
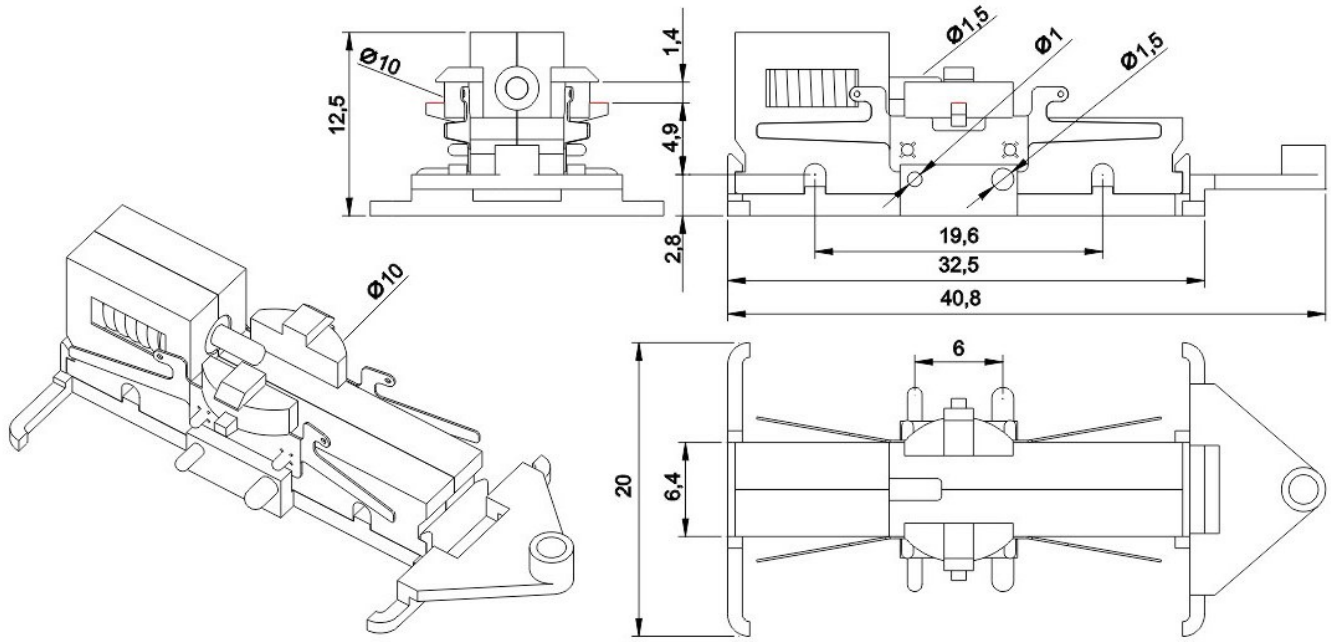

ANT-K-H0x - 41,4mm:

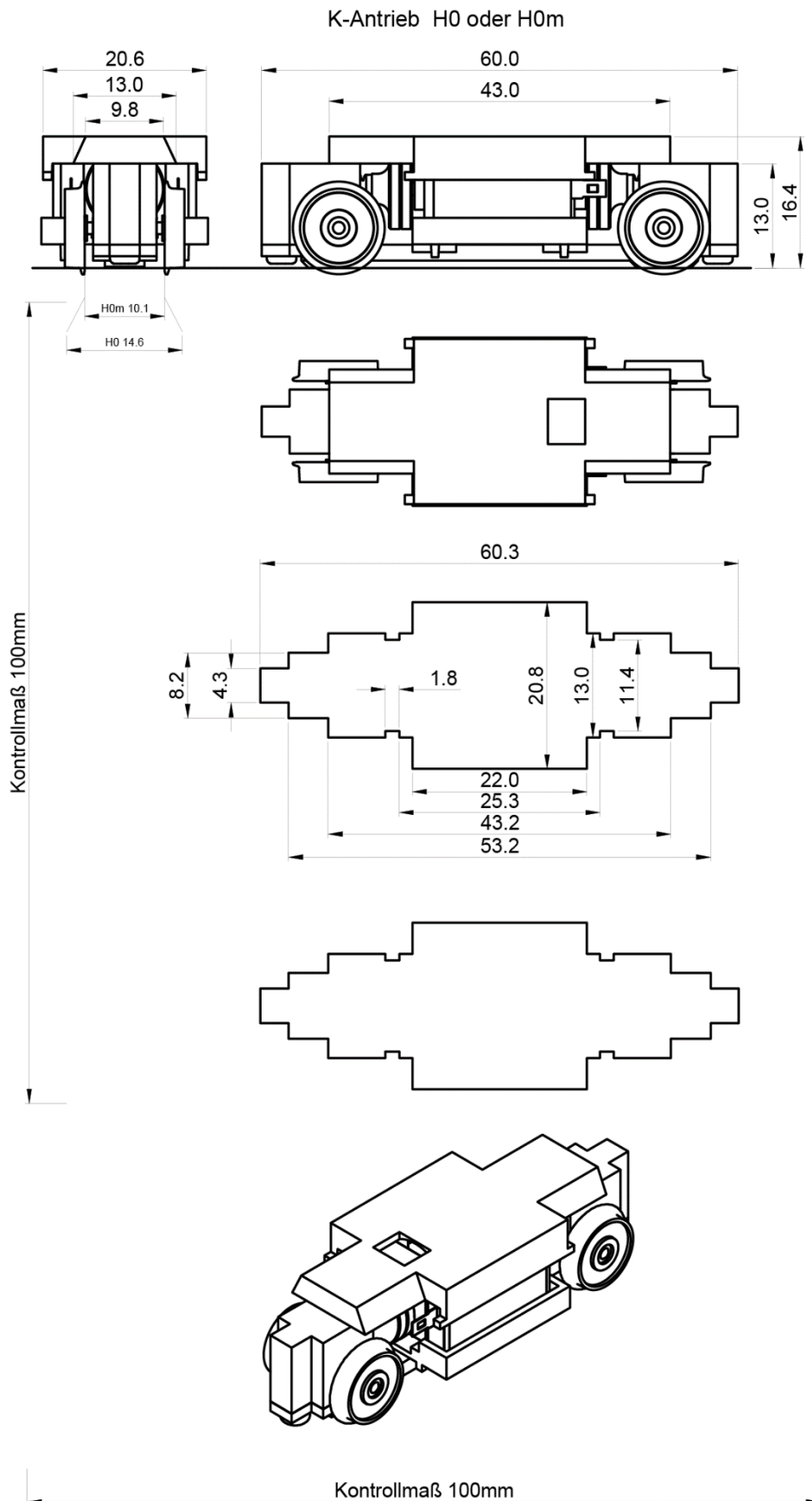

ANT-KSW-H0x – 35 mm:

KSW-Antrieb H0 oder H0m

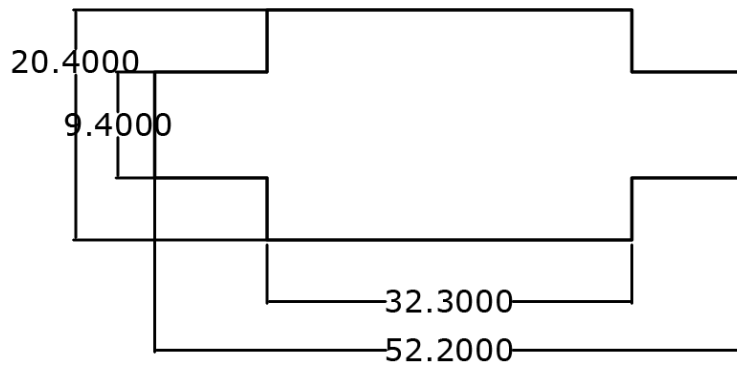
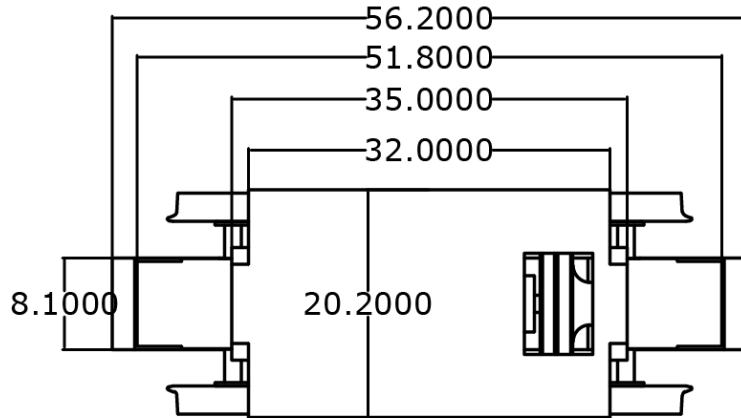
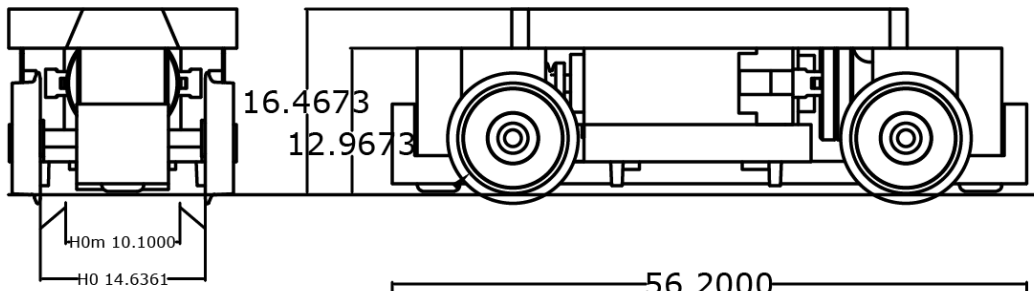

Kontrollmaß 100mm

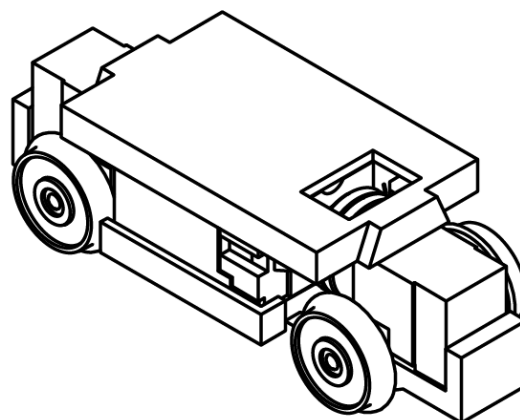

Kontrollmaß 100mm

ANT-27-H0x – 27 mm:

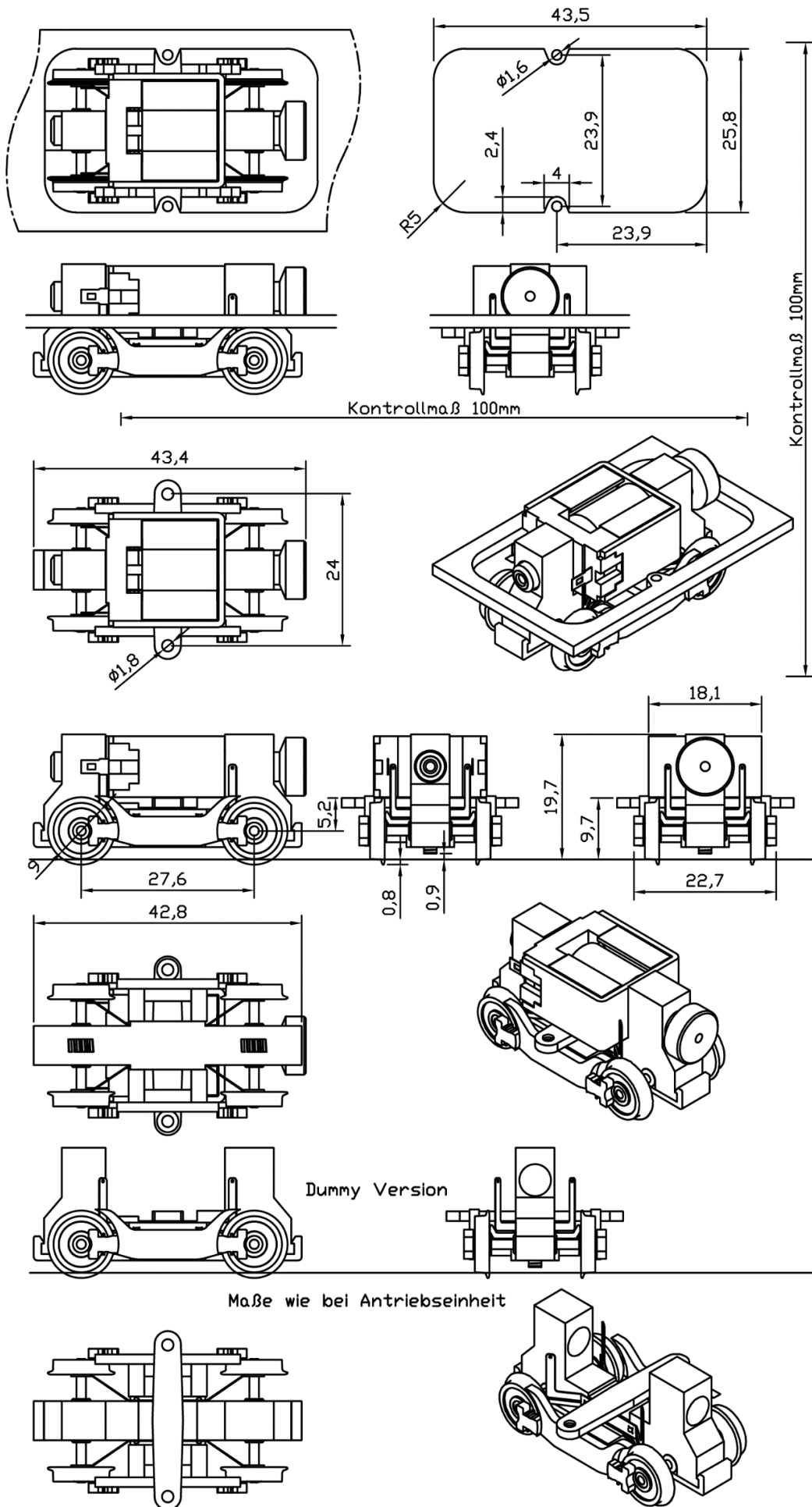

ANT-STx-H0x – 21,7 mm:

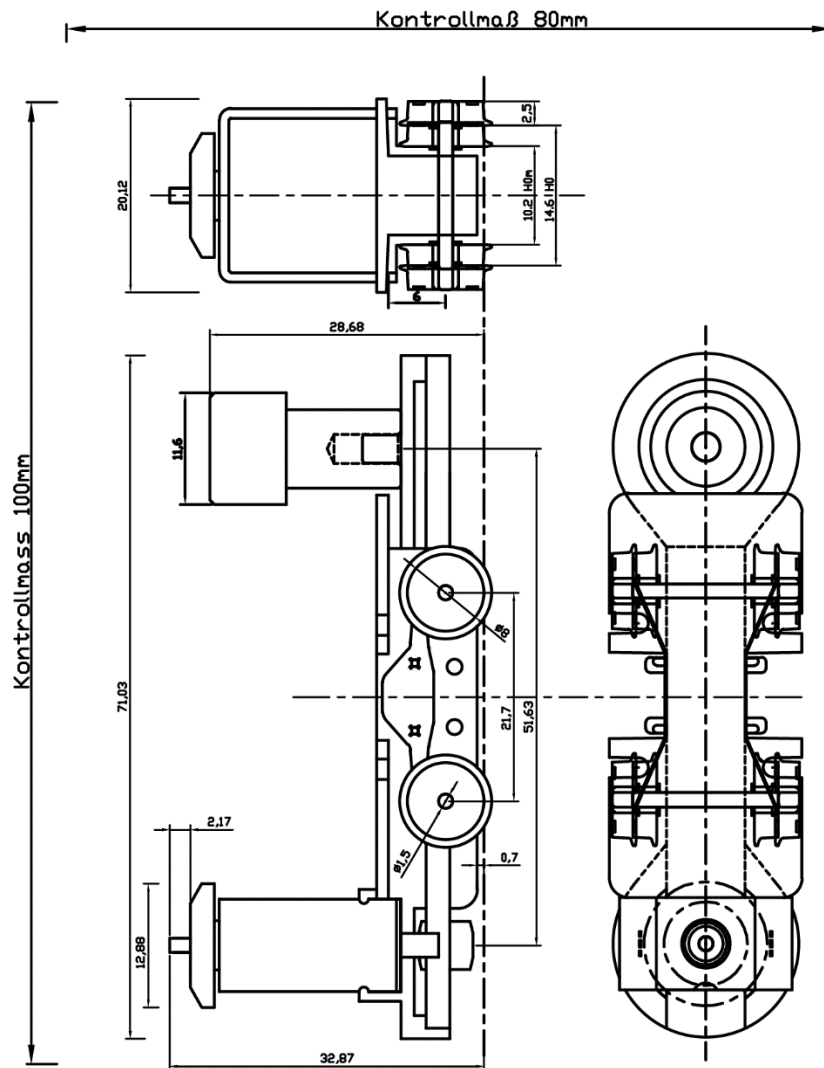

ANT-KOP-X:

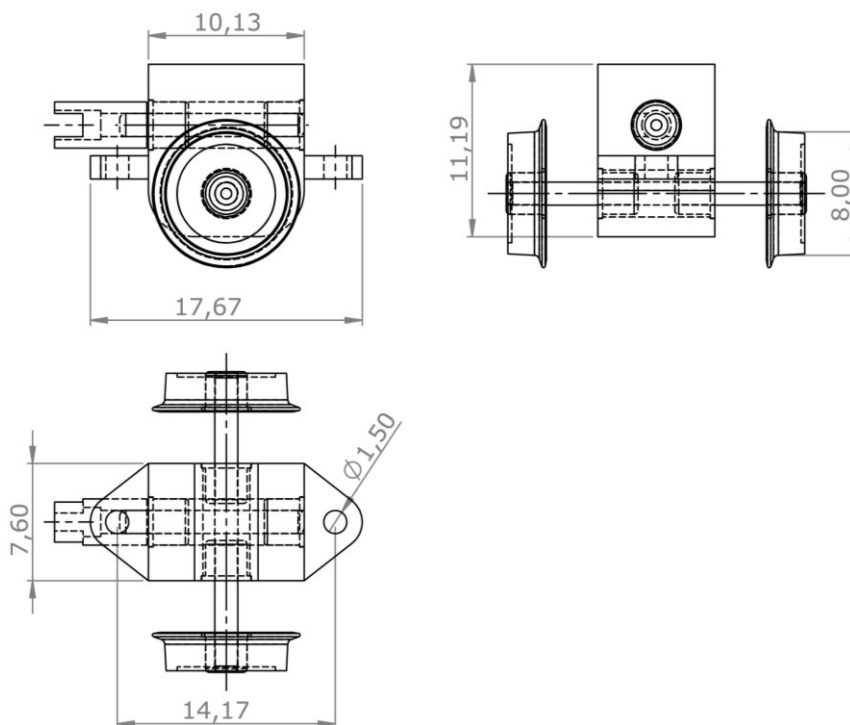

ANT-VAR-H0x-xx-DG – 23,1/26,8/30,5 mm:

Kontrollmaß 150mm

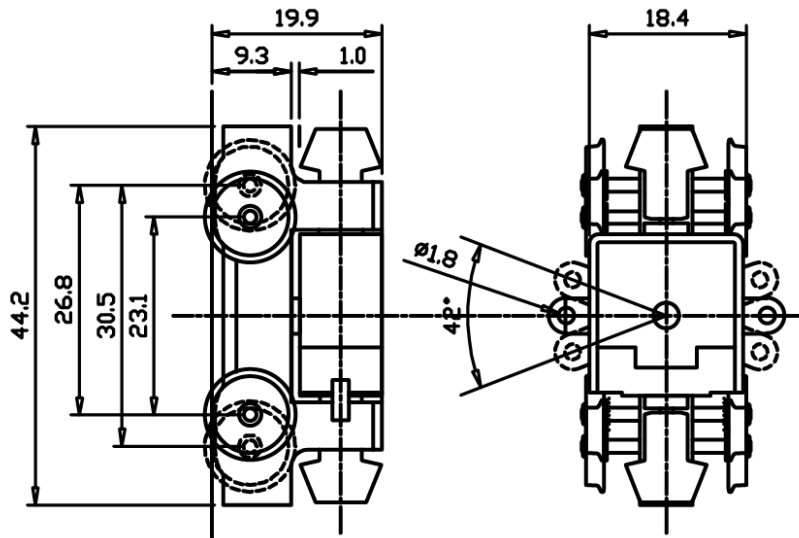

A = Achsabstand 23.1

B = Achsabstand 30.5

Drehwinkel +/-21°

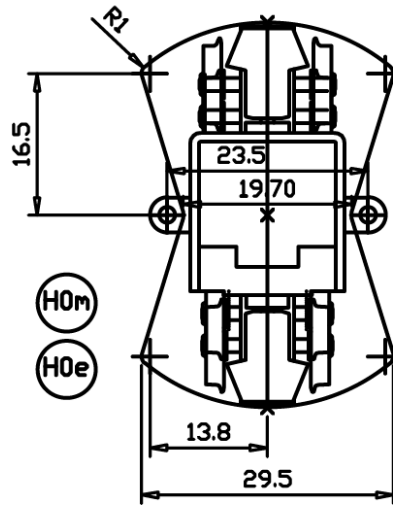
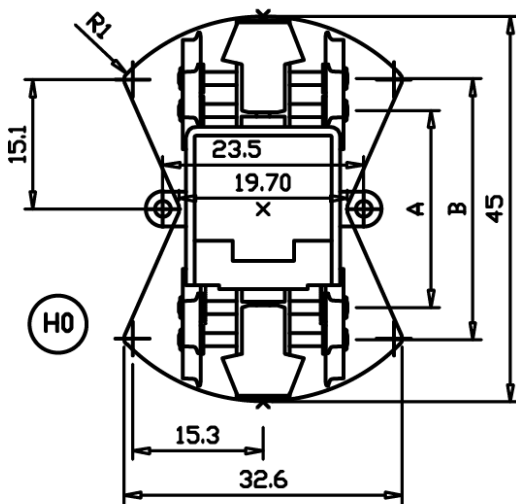

Kontrollmaß 175mm

ANT-VAR-H0x-xx – 23,1/26,8/30,5 mm:

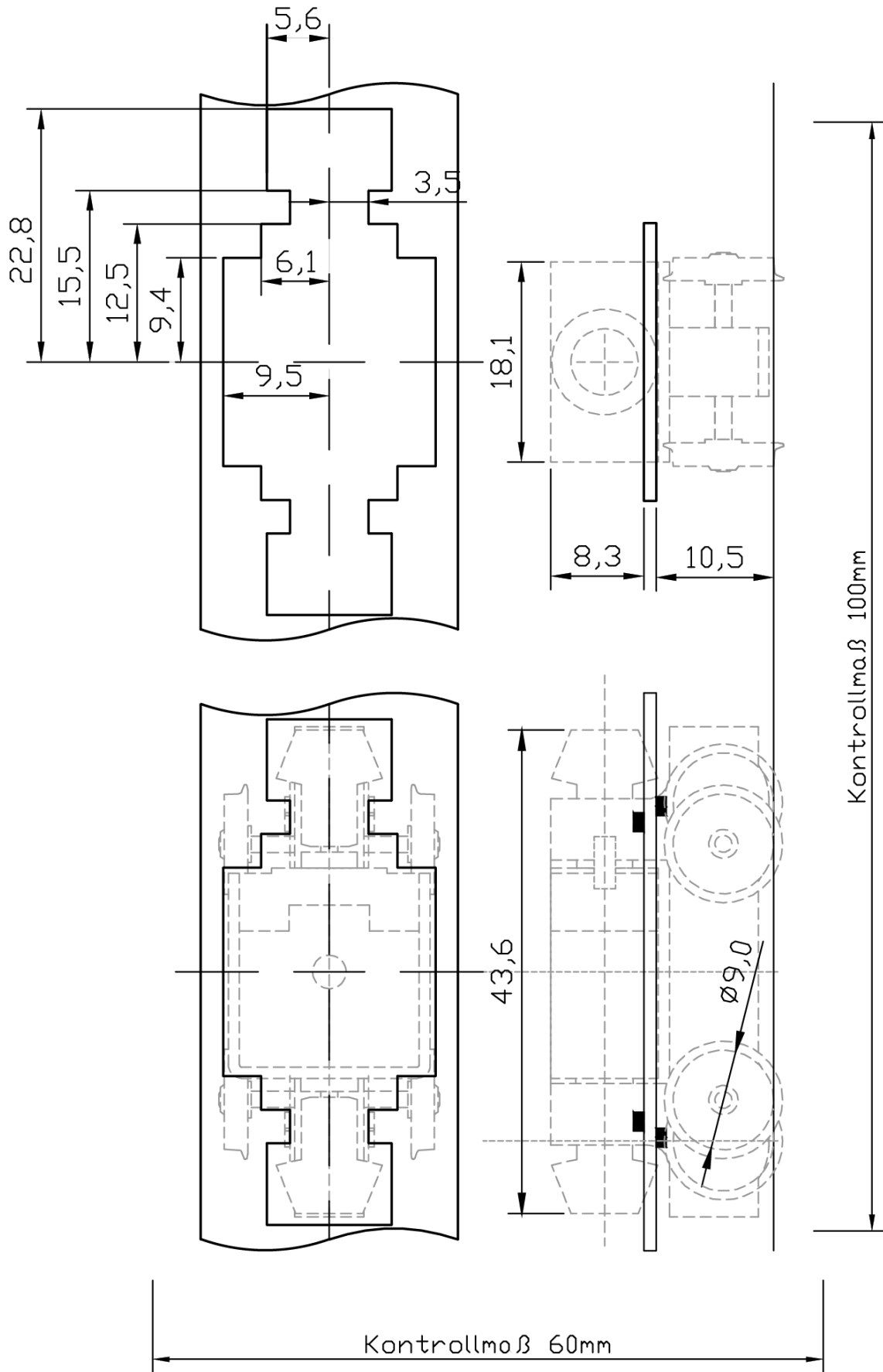

ANT-E-H0x:

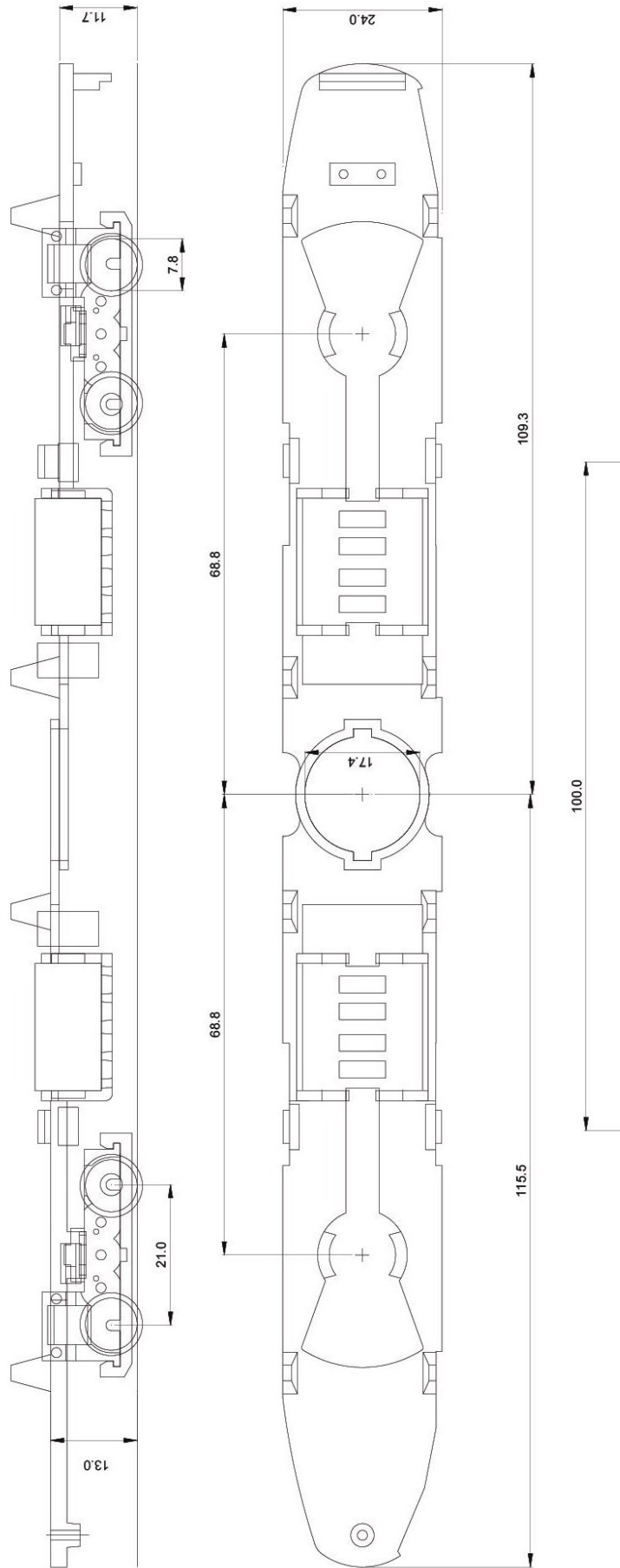

ANT-C1-M-H0x:

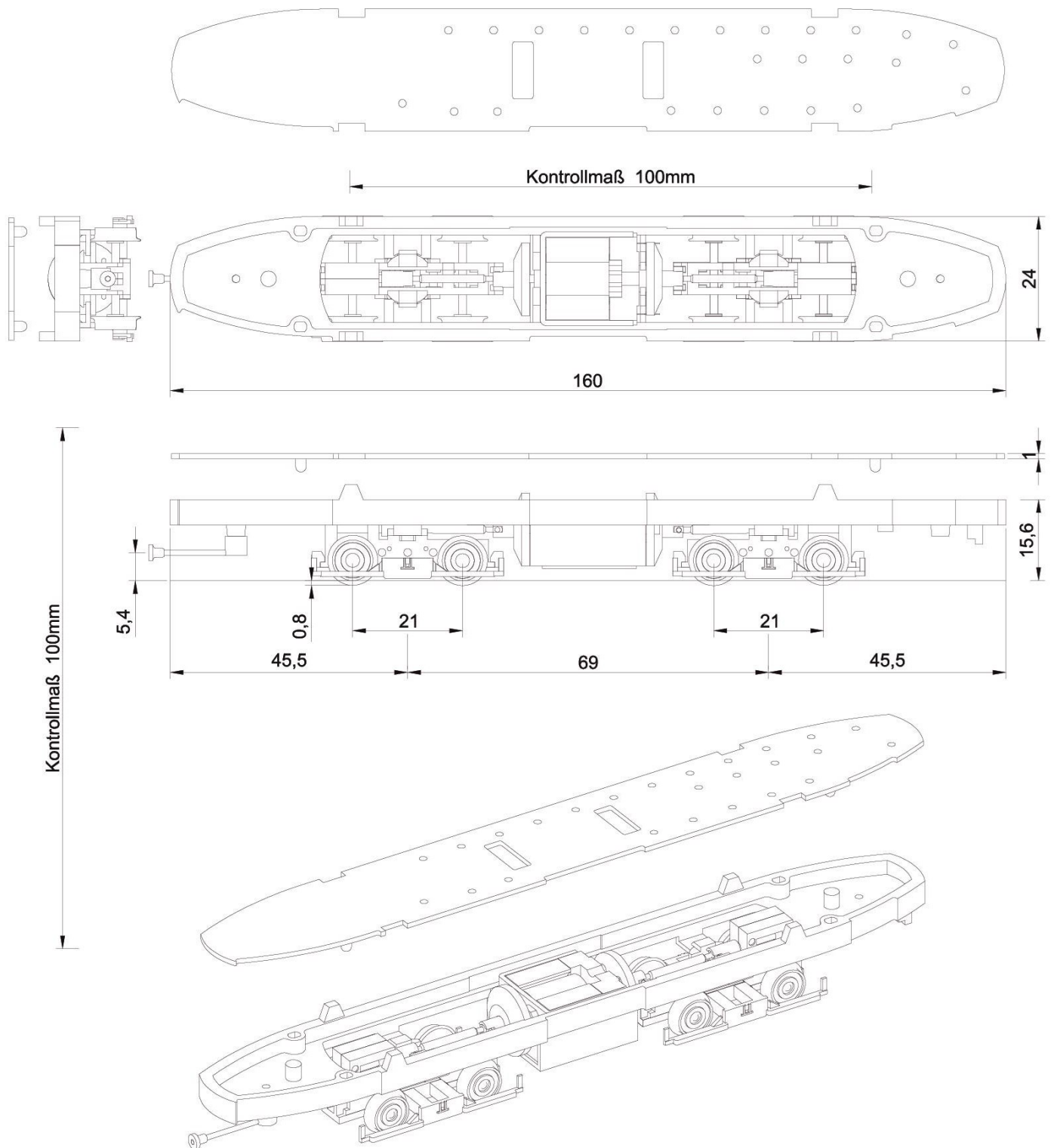

ANT-C1-B-H0x:

