



HALLING MODELLE

Straßenbahn - Eisenbahn - Schmalspurbahn - Antriebe

Mix&Match
OLDTIMER-KATALOG
2021





HALLING MODELLE

Straßenbahn - Eisenbahn - Schmalspurbahn - Antriebe

Kontakt / Contact

LEOPOLD HALLING GmbH.
 Leopoldgasse 15-17, 1230 Wien, Österreich
 Mo.-Fr. 08:00-12:00
 (Abholung reservierter Ware bis 16:00 und nach Vereinbarung)
 E-Mail: office@halling.at
 Tel.: (+43) (1) 604 31 22 - www.halling.at

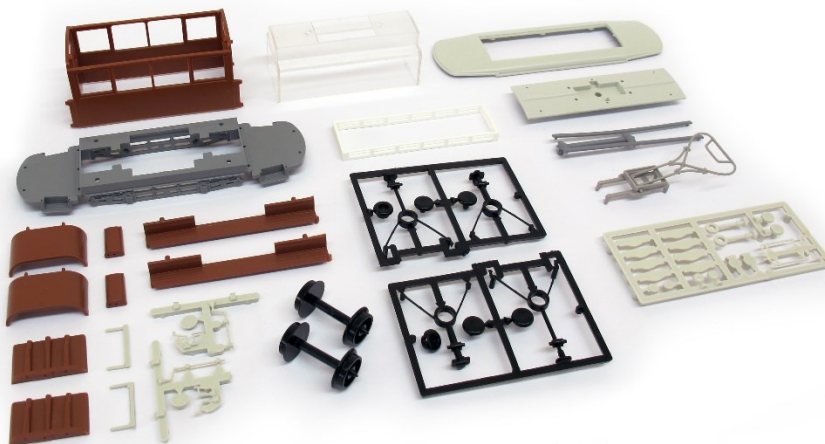

Die vielen kleinen Oldtimer von HALLING Modelle waren immer das Steckenpferd des Firmengründers Leopold Halling. Mit großer Freude und viel Geduld fertigte er die hochdetaillierten und aufwändig gestalteten Modelle höchstpersönlich. Alle in der Firma wussten:



„Die Oldtimer sind Chefsache!“

Die Neuentwicklung der Modelle lief immer nebenbei und sollte möglichst wenig kosten. So hat HALLING Modelle über Jahrzehnte einen in sich schlüssigen Bausatz aus Oldtimerteilen geschaffen, die alle zusammenpassen. Ob dieser oder jener Wagenkasten, alle passen auf die Chassis. Eine geschlossene Fahrerkabine, oder die offenen Bühne aus längst vergangenen Tagen? Kein Problem, die Steckverbindungen sind genormt!

Erstmals soll dieser Baukasten nun öffentlich zugänglich gemacht werden. Für kleines Geld kann ein eigener Oldtimer-Teilesatz zusammengestellt werden, denn eines ist offensichtlich: selbst nachdem über hundert unterschiedliche Oldtimer-Trams im Modell umgesetzt wurden, gibt es immer noch hunderte die noch darauf warten, verwirklicht zu werden.

Zur farblichen Gestaltung können selbst gemachte, hochdeckende Decals von HALLING Modelle verwendet werden. Eine Anleitung zur Herstellung kann man auf der neuen Homepage www.halling.at herunterladen.



The numerous small Oldtimers Trams from HALLING Modelle always were the hobby of the company founder Leopold Halling Senior. With great joy and a lot of patience, he personally made the highly detailed and lavishly designed models. Everyone in the company knew:



"The oldtimer trams are a matter for the boss!"

New developments for these models were always done on the side and should cost as little as possible. Over the decades, HALLING Modelle has created a coherent kit of classic tram parts that all fit together. Whether this or that car body, they all fit on the chassis. A closed driver's cab or the open cockpit from days long gone? No problem, the plug connections are standardized!

For the first time, this kit is to be made publicly available. You can put together your own set of tram parts for little money, because one thing is obvious: even after over a hundred different oldtimer trams have been honoured by a model, there are still hundreds waiting to be implemented.

Self-made, high-coverage decals from HALLING Modelle can be used for the colour design. Instructions for presentation can be downloaded from the new homepage www.halling.at.

Wagenkästen / Car Bodies

<p>Oldtimer Straßenbahn Wagenkasten 303-A</p> <p>Wagenkasten für historische Straßenbahnen, passend zu Bauteilen aus dem Mix&Match Oldtimer-Katalog, gemäß Abbildung, Farbe kann abweichen.</p>	
<p>Vintage tram car body 303-A</p> <p><i>Car body for historic trams, suitable for components from the Mix & Match oldtimer catalog, according to illustration, color may vary.</i></p>	
<p style="text-align: right;">OLD-303-A € 4,00</p>	
<p>Oldtimer Straßenbahn Wagenkasten 304-A</p> <p>Wagenkasten für historische Straßenbahnen, passend zu Bauteilen aus dem Mix&Match Oldtimer-Katalog, gemäß Abbildung, Farbe kann abweichen.</p>	
<p>Vintage tram car body 304-A</p> <p><i>Car body for historic trams, suitable for components from the Mix & Match oldtimer catalog, according to illustration, color may vary.</i></p>	
<p style="text-align: right;">OLD-304-A € 4,00</p>	
<p>Oldtimer Straßenbahn Wagenkasten 305-A</p> <p>Wagenkasten für historische Straßenbahnen, passend zu Bauteilen aus dem Mix&Match Oldtimer-Katalog, gemäß Abbildung, Farbe kann abweichen.</p>	
<p>Vintage tram car body 305-A</p> <p><i>Car body for historic trams, suitable for components from the Mix & Match oldtimer catalog, according to illustration, color may vary.</i></p>	
<p style="text-align: right;">OLD-305-A € 4,00</p>	
<p>Oldtimer Straßenbahn Wagenkasten 307-A</p> <p>Wagenkasten für historische Straßenbahnen, passend zu Bauteilen aus dem Mix&Match Oldtimer-Katalog, gemäß Abbildung, Farbe kann abweichen.</p>	
<p>Vintage tram car body 307-A</p> <p><i>Car body for historic trams, suitable for components from the Mix & Match oldtimer catalog, according to illustration, color may vary.</i></p>	
<p style="text-align: right;">OLD-307-A € 4,00</p>	

Wagenkästen / Car Bodies

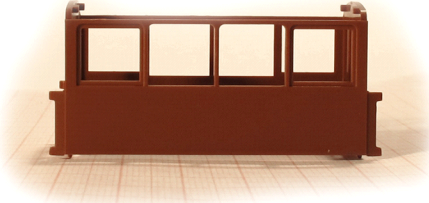
Oldtimer Straßenbahn Wagenkasten 308-A		
Wagenkasten für historische Straßenbahnen, passend zu Bauteilen aus dem Mix&Match Oldtimer-Katalog, gemäß Abbildung, Farbe kann abweichen.		
Vintage tram car body 308-A		
<i>Car body for historic trams, suitable for components from the Mix & Match oldtimer catalog, according to illustration, color may vary.</i>		
OLD-308-A	€ 4,00	

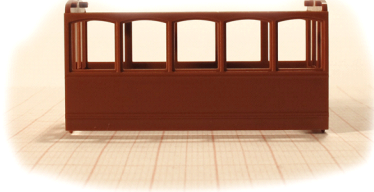
Oldtimer Straßenbahn Wagenkasten 309-A		
Wagenkasten für historische Straßenbahnen, passend zu Bauteilen aus dem Mix&Match Oldtimer-Katalog, gemäß Abbildung, Farbe kann abweichen.		
Vintage tram car body 309-A		
<i>Car body for historic trams, suitable for components from the Mix & Match oldtimer catalog, according to illustration, color may vary.</i>		
OLD-309-A	€ 4,00	

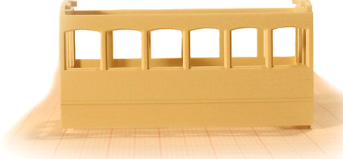
Oldtimer Straßenbahn Wagenkasten 312-A		
Wagenkasten für historische Straßenbahnen, passend zu Bauteilen aus dem Mix&Match Oldtimer-Katalog, gemäß Abbildung, Farbe kann abweichen.		
Vintage tram car body 312-A		
<i>Car body for historic trams, suitable for components from the Mix & Match oldtimer catalog, according to illustration, color may vary.</i>		
OLD-312-A	€ 4,00	

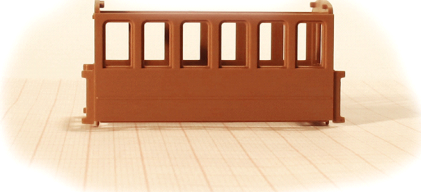
Oldtimer Straßenbahn Wagenkasten 313-A		
Wagenkasten für historische Straßenbahnen, passend zu Bauteilen aus dem Mix&Match Oldtimer-Katalog, gemäß Abbildung, Farbe kann abweichen.		
Vintage tram car body 313-A		
<i>Car body for historic trams, suitable for components from the Mix & Match oldtimer catalog, according to illustration, color may vary.</i>		
OLD-313-A	€ 4,00	

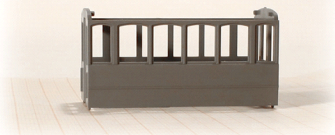
Oldtimer Straßenbahn Wagenkasten 314-A		
Wagenkasten für historische Straßenbahnen, passend zu Bauteilen aus dem Mix&Match Oldtimer-Katalog, gemäß Abbildung, Farbe kann abweichen.		
Vintage tram car body 314-A		
<i>Car body for historic trams, suitable for components from the Mix & Match oldtimer catalog, according to illustration, color may vary.</i>		
OLD-314-A	€ 4,00	

Wagenkästen / Car Bodies

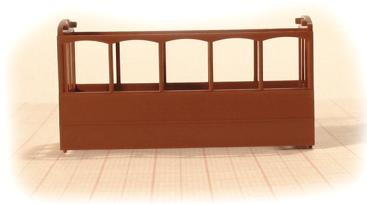
Oldtimer Straßenbahn Wagenkasten 315-A		
Wagenkasten für historische Straßenbahnen, passend zu Bauteilen aus dem Mix&Match Oldtimer-Katalog, gemäß Abbildung, Farbe kann abweichen.		
Vintage tram car body 315-A		
<i>Car body for historic trams, suitable for components from the Mix & Match oldtimer catalog, according to illustration, color may vary.</i>		
OLD-315-A	€ 4,00	

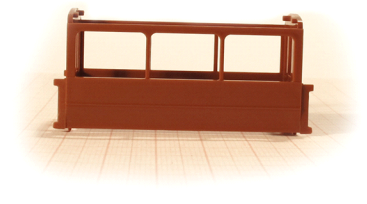
Oldtimer Straßenbahn Wagenkasten 316-A		
Wagenkasten für historische Straßenbahnen, passend zu Bauteilen aus dem Mix&Match Oldtimer-Katalog, gemäß Abbildung, Farbe kann abweichen.		
Vintage tram car body 316-A		
<i>Car body for historic trams, suitable for components from the Mix & Match oldtimer catalog, according to illustration, color may vary.</i>		
OLD-316-A	€ 4,00	

Oldtimer Straßenbahn Wagenkasten 317-A		
Wagenkasten für historische Straßenbahnen, passend zu Bauteilen aus dem Mix&Match Oldtimer-Katalog, gemäß Abbildung, Farbe kann abweichen.		
Vintage tram car body 317-A		
<i>Car body for historic trams, suitable for components from the Mix & Match oldtimer catalog, according to illustration, color may vary.</i>		
OLD-317-A	€ 4,00	

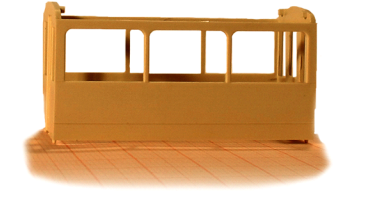
Oldtimer Straßenbahn Wagenkasten 318-A		
Wagenkasten für historische Straßenbahnen, passend zu Bauteilen aus dem Mix&Match Oldtimer-Katalog, gemäß Abbildung, Farbe kann abweichen.		
Vintage tram car body 318-A		
<i>Car body for historic trams, suitable for components from the Mix & Match oldtimer catalog, according to illustration, color may vary.</i>		
OLD-318-A	€ 4,00	

Oldtimer Straßenbahn Wagenkasten 319-A		
Wagenkasten für historische Straßenbahnen, passend zu Bauteilen aus dem Mix&Match Oldtimer-Katalog, gemäß Abbildung, Farbe kann abweichen.		
Vintage tram car body 319-A		
<i>Car body for historic trams, suitable for components from the Mix & Match oldtimer catalog, according to illustration, color may vary.</i>		
OLD-319-A	€ 4,00	

Wagenkästen / Car Bodies

Oldtimer Straßenbahn Wagenkasten 320-A		
Wagenkasten für historische Straßenbahnen, passend zu Bauteilen aus dem Mix&Match Oldtimer-Katalog, gemäß Abbildung, Farbe kann abweichen.		
Vintage tram car body 320-A		
<i>Car body for historic trams, suitable for components from the Mix & Match oldtimer catalog, according to illustration, color may vary.</i>		
OLD-320-A	€ 4,00	

Oldtimer Straßenbahn Wagenkasten 321-A		
Wagenkasten für historische Straßenbahnen, passend zu Bauteilen aus dem Mix&Match Oldtimer-Katalog, gemäß Abbildung, Farbe kann abweichen.		
Vintage tram car body 321-A		
<i>Car body for historic trams, suitable for components from the Mix & Match oldtimer catalog, according to illustration, color may vary.</i>		
OLD-321-A	€ 4,00	

Oldtimer Straßenbahn Wagenkasten 322-A		
Wagenkasten für historische Straßenbahnen, passend zu Bauteilen aus dem Mix&Match Oldtimer-Katalog, gemäß Abbildung, Farbe kann abweichen.		
Vintage tram car body 322-A		
<i>Car body for historic trams, suitable for components from the Mix & Match oldtimer catalog, according to illustration, color may vary.</i>		
OLD-322-A	€ 4,00	

Oldtimer Straßenbahn Wagenkasten 323-A		
Wagenkasten für historische Straßenbahnen, passend zu Bauteilen aus dem Mix&Match Oldtimer-Katalog, gemäß Abbildung, Farbe kann abweichen.		
Vintage tram car body 323-A		
<i>Car body for historic trams, suitable for components from the Mix & Match oldtimer catalog, according to illustration, color may vary.</i>		
OLD-323-A	€ 4,00	

Oldtimer Straßenbahn Wagenkasten 324-A		
Wagenkasten für historische Straßenbahnen, passend zu Bauteilen aus dem Mix&Match Oldtimer-Katalog, gemäß Abbildung, Farbe kann abweichen.		
Vintage tram car body 324-A		
<i>Car body for historic trams, suitable for components from the Mix & Match oldtimer catalog, according to illustration, color may vary.</i>		
OLD-324-A	€ 4,00	

Wagenkästen / Car Bodies

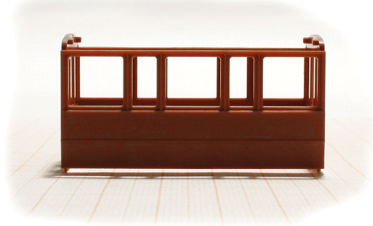
Oldtimer Straßenbahn Wagenkasten 325-A		
Wagenkasten für historische Straßenbahnen, passend zu Bauteilen aus dem Mix&Match Oldtimer-Katalog, gemäß Abbildung, Farbe kann abweichen.		
Vintage tram car body 325-A		
<i>Car body for historic trams, suitable for components from the Mix & Match oldtimer catalog, according to illustration, color may vary.</i>		
OLD-325-A	€ 4,00	

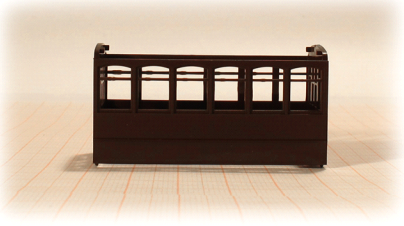
Oldtimer Straßenbahn Wagenkasten 326-A		
Wagenkasten für historische Straßenbahnen, passend zu Bauteilen aus dem Mix&Match Oldtimer-Katalog, gemäß Abbildung, Farbe kann abweichen.		
Vintage tram car body 326-A		
<i>Car body for historic trams, suitable for components from the Mix & Match oldtimer catalog, according to illustration, color may vary.</i>		
OLD-326-A	€ 4,00	

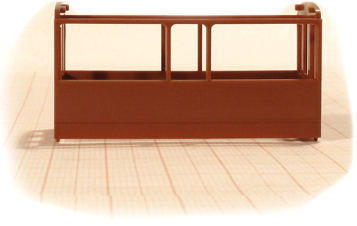
Oldtimer Straßenbahn Wagenkasten 327-A		
Wagenkasten für historische Straßenbahnen, passend zu Bauteilen aus dem Mix&Match Oldtimer-Katalog, gemäß Abbildung, Farbe kann abweichen.		
Vintage tram car body 327-A		
<i>Car body for historic trams, suitable for components from the Mix & Match oldtimer catalog, according to illustration, color may vary.</i>		
OLD-327-A	€ 4,00	

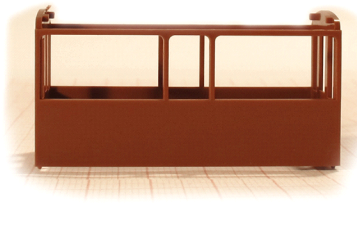
Oldtimer Straßenbahn Wagenkasten 328-A		
Wagenkasten für historische Straßenbahnen, passend zu Bauteilen aus dem Mix&Match Oldtimer-Katalog, gemäß Abbildung, Farbe kann abweichen.		
Vintage tram car body 328-A		
<i>Car body for historic trams, suitable for components from the Mix & Match oldtimer catalog, according to illustration, color may vary.</i>		
OLD-328-A	€ 4,00	

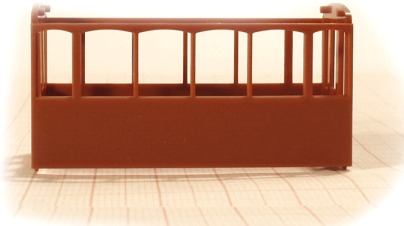
Oldtimer Straßenbahn Wagenkasten 329-A		
Wagenkasten für historische Straßenbahnen, passend zu Bauteilen aus dem Mix&Match Oldtimer-Katalog, gemäß Abbildung, Farbe kann abweichen.		
Vintage tram car body 329-A		
<i>Car body for historic trams, suitable for components from the Mix & Match oldtimer catalog, according to illustration, color may vary.</i>		
OLD-329-A	€ 4,00	

Wagenkästen / Car Bodies

Oldtimer Straßenbahn Wagenkasten 330-A		
Wagenkasten für historische Straßenbahnen, passend zu Bauteilen aus dem Mix&Match Oldtimer-Katalog, gemäß Abbildung, Farbe kann abweichen.		
Vintage tram car body 330-A		
<i>Car body for historic trams, suitable for components from the Mix & Match oldtimer catalog, according to illustration, color may vary.</i>		
OLD-330-A	€ 4,00	

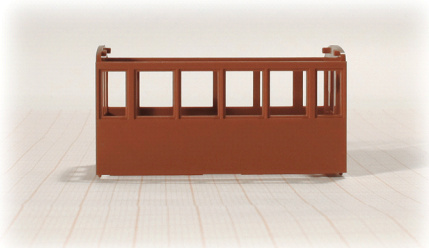
Oldtimer Straßenbahn Wagenkasten 331-A		
Wagenkasten für historische Straßenbahnen, passend zu Bauteilen aus dem Mix&Match Oldtimer-Katalog, gemäß Abbildung, Farbe kann abweichen.		
Vintage tram car body 331-A		
<i>Car body for historic trams, suitable for components from the Mix & Match oldtimer catalog, according to illustration, color may vary.</i>		
OLD-331-A	€ 4,00	

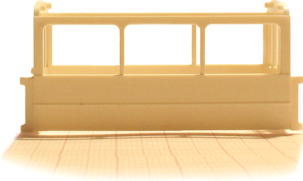
Oldtimer Straßenbahn Wagenkasten 332-A		
Wagenkasten für historische Straßenbahnen, passend zu Bauteilen aus dem Mix&Match Oldtimer-Katalog, gemäß Abbildung, Farbe kann abweichen.		
Vintage tram car body 332-A		
<i>Car body for historic trams, suitable for components from the Mix & Match oldtimer catalog, according to illustration, color may vary.</i>		
OLD-332-A	€ 4,00	

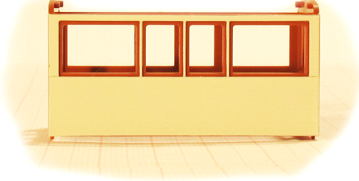
Oldtimer Straßenbahn Wagenkasten 333-A		
Wagenkasten für historische Straßenbahnen, passend zu Bauteilen aus dem Mix&Match Oldtimer-Katalog, gemäß Abbildung, Farbe kann abweichen.		
Vintage tram car body 333-A		
<i>Car body for historic trams, suitable for components from the Mix & Match oldtimer catalog, according to illustration, color may vary.</i>		
OLD-333-A	€ 4,00	

Oldtimer Straßenbahn Wagenkasten 334-A		
Wagenkasten für historische Straßenbahnen, passend zu Bauteilen aus dem Mix&Match Oldtimer-Katalog, gemäß Abbildung, Farbe kann abweichen.		
Vintage tram car body 334-A		
<i>Car body for historic trams, suitable for components from the Mix & Match oldtimer catalog, according to illustration, color may vary.</i>		
OLD-334-A	€ 4,00	

Wagenkästen / Car Bodies

Oldtimer Straßenbahn Wagenkasten 335-A		
Wagenkasten für historische Straßenbahnen, passend zu Bauteilen aus dem Mix&Match Oldtimer-Katalog, gemäß Abbildung, Farbe kann abweichen.		
Vintage tram car body 335-A		
<i>Car body for historic trams, suitable for components from the Mix & Match oldtimer catalog, according to illustration, color may vary.</i>		
OLD-335-A	€ 4,00	

Oldtimer Straßenbahn Wagenkasten 336-A		
Wagenkasten für historische Straßenbahnen, passend zu Bauteilen aus dem Mix&Match Oldtimer-Katalog, gemäß Abbildung, Farbe kann abweichen.		
Vintage tram car body 336-A		
<i>Car body for historic trams, suitable for components from the Mix & Match oldtimer catalog, according to illustration, color may vary.</i>		
OLD-336-A	€ 4,00	

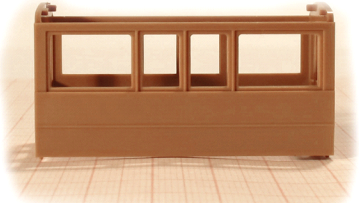
Oldtimer Straßenbahn Wagenkasten 337-A		
Wagenkasten für historische Straßenbahnen, passend zu Bauteilen aus dem Mix&Match Oldtimer-Katalog, gemäß Abbildung, Farbe kann abweichen.		
Vintage tram car body 337-A		
<i>Car body for historic trams, suitable for components from the Mix & Match oldtimer catalog, according to illustration, color may vary.</i>		
OLD-337-A	€ 4,00	

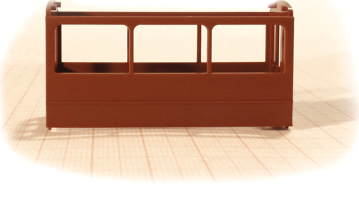
Oldtimer Straßenbahn Wagenkasten 339-A		
Wagenkasten für historische Straßenbahnen, passend zu Bauteilen aus dem Mix&Match Oldtimer-Katalog, gemäß Abbildung, Farbe kann abweichen.		
Vintage tram car body 339-A		
<i>Car body for historic trams, suitable for components from the Mix & Match oldtimer catalog, according to illustration, color may vary.</i>		
OLD-339-A	€ 4,00	

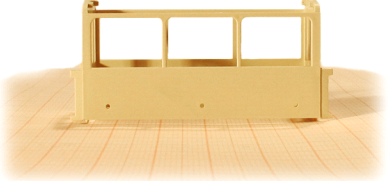
Oldtimer Straßenbahn Wagenkasten 341-A		
Wagenkasten für historische Straßenbahnen, passend zu Bauteilen aus dem Mix&Match Oldtimer-Katalog, gemäß Abbildung, Farbe kann abweichen.		
Vintage tram car body 341-A		
<i>Car body for historic trams, suitable for components from the Mix & Match oldtimer catalog, according to illustration, color may vary.</i>		
OLD-341-A	€ 4,00	

Wagenkästen / Car Bodies

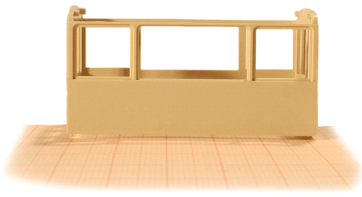
Oldtimer Straßenbahn Wagenkasten 342-A		
Wagenkasten für historische Straßenbahnen, passend zu Bauteilen aus dem Mix&Match Oldtimer-Katalog, gemäß Abbildung, Farbe kann abweichen.		
Vintage tram car body 342-A		
<i>Car body for historic trams, suitable for components from the Mix & Match oldtimer catalog, according to illustration, color may vary.</i>		
OLD-342-A	€ 4,00	

Dächer / Roofs

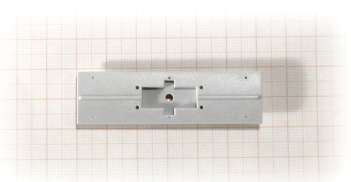
Oldtimer Straßenbahn Dach 201-A		
Dach für historische Straßenbahnen, passend zu Bauteilen aus dem Mix&Match Oldtimer-Katalog, gemäß Abbildung, Farbe kann abweichen.		
Vintage tram car roof 201-A		
<i>Car roof for historic trams, suitable for components from the Mix & Match oldtimer catalog, according to illustration, color may vary.</i>		
OLD-201-A	€ 3,00	

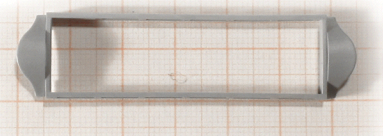
Oldtimer Straßenbahn Zwischendach 204-A		
Dach für historische Straßenbahnen, passend zu Bauteilen aus dem Mix&Match Oldtimer-Katalog, gemäß Abbildung, Farbe kann abweichen.		
Vintage tram car roof 204-A		
<i>between roof for historic trams, suitable for components from the Mix & Match oldtimer catalog, according to illustration, color may vary.</i>		
OLD-204-A	€ 3,00	

Oldtimer Straßenbahn Zwischendach 204-B		
Dach für historische Straßenbahnen, passend zu Bauteilen aus dem Mix&Match Oldtimer-Katalog, gemäß Abbildung, Farbe kann abweichen.		
Vintage tram car roof 204-B		
<i>between roof for historic trams, suitable for components from the Mix & Match oldtimer catalog, according to illustration, color may vary.</i>		
OLD-204-B	€ 3,00	

Oldtimer Straßenbahn Dach 205-A		
Dach für historische Straßenbahnen, passend zu Bauteilen aus dem Mix&Match Oldtimer-Katalog, gemäß Abbildung, Farbe kann abweichen.		
Vintage tram car roof 205-A		
<i>Car roof for historic trams, suitable for components from the Mix & Match oldtimer catalog, according to illustration, color may vary.</i>		
OLD-205-A	€ 3,00	

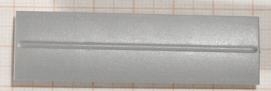
Oldtimer Straßenbahn Dach 206-A		
Dach für historische Straßenbahnen, passend zu Bauteilen aus dem Mix&Match Oldtimer-Katalog, gemäß Abbildung, Farbe kann abweichen.		
Vintage tram car roof 206-A		
<i>Car roof for historic trams, suitable for components from the Mix & Match oldtimer catalog, according to illustration, color may vary.</i>		
OLD-206-A	€ 3,00	

Dächer / Roofs

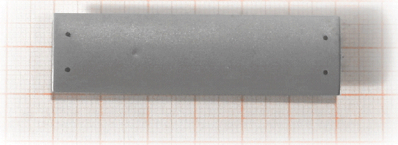
Oldtimer Straßenbahn Dach 210-A		
Dach für historische Straßenbahnen, passend zu Bauteilen aus dem Mix&Match Oldtimer-Katalog, gemäß Abbildung, Farbe kann abweichen.		
Vintage tram car roof 210-A		
<i>Car roof for historic trams, suitable for components from the Mix & Match oldtimer catalog, according to illustration, color may vary.</i>		
OLD-210-A	€ 3,00	

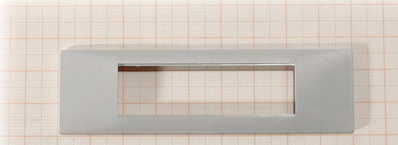
Oldtimer Straßenbahn Dach 214-A		
Dach für historische Straßenbahnen, passend zu Bauteilen aus dem Mix&Match Oldtimer-Katalog, gemäß Abbildung, Farbe kann abweichen.		
Vintage tram car roof 214-A		
<i>Car roof for historic trams, suitable for components from the Mix & Match oldtimer catalog, according to illustration, color may vary.</i>		
OLD-214-A	€ 3,00	

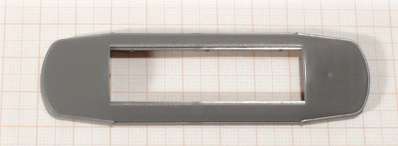
Oldtimer Straßenbahn Dach 215-A		
Dach für historische Straßenbahnen, passend zu Bauteilen aus dem Mix&Match Oldtimer-Katalog, gemäß Abbildung, Farbe kann abweichen.		
Vintage tram car roof 215-A		
<i>Car roof for historic trams, suitable for components from the Mix & Match oldtimer catalog, according to illustration, color may vary.</i>		
OLD-215-A	€ 3,00	

Chassis / Chassis

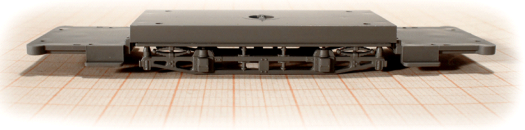
Oldtimer Straßenbahn Bodenplatte 101-B		
Bodenplatte für historische Straßenbahnen, passend zu Bauteilen aus dem Mix&Match Oldtimer-Katalog, gemäß Abbildung, Farbe kann abweichen.		
Vintage tram Base plate 101-B		
<i>Base plate for historic trams, suitable for components from the Mix & Match oldtimer catalog, according to illustration, color may vary.</i>		
OLD-101-B	€ 4,00	

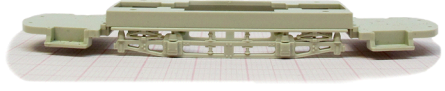
Oldtimer Straßenbahn Bodenplatte 101-C		
Bodenplatte für historische Straßenbahnen, passend zu Bauteilen aus dem Mix&Match Oldtimer-Katalog, gemäß Abbildung, Farbe kann abweichen.		
Vintage tram Base plate 101-C		
<i>Base plate for historic trams, suitable for components from the Mix & Match oldtimer catalog, according to illustration, color may vary.</i>		
OLD-101-C	€ 4,00	

Oldtimer Straßenbahn Bodenplatte 101-D		
Bodenplatte für historische Straßenbahnen, passend zu Bauteilen aus dem Mix&Match Oldtimer-Katalog, gemäß Abbildung, Farbe kann abweichen.		
Vintage tram Base plate 101-D		
<i>Base plate for historic trams, suitable for components from the Mix & Match oldtimer catalog, according to illustration, color may vary.</i>		
OLD-101-D	€ 4,00	

Oldtimer Straßenbahn Bodenplatte 101-E		
Bodenplatte für historische Straßenbahnen, passend zu Bauteilen aus dem Mix&Match Oldtimer-Katalog, gemäß Abbildung, Farbe kann abweichen.		
Vintage tram Base plate 101-E		
<i>Base plate for historic trams, suitable for components from the Mix & Match oldtimer catalog, according to illustration, color may vary.</i>		
OLD-101-E	€ 4,00	

Oldtimer Straßenbahn Bodenplatte 103-F		
Bodenplatte für historische Straßenbahnen, passend zu Bauteilen aus dem Mix&Match Oldtimer-Katalog, gemäß Abbildung, Farbe kann abweichen.		
Vintage tram Base plate 103-F		
<i>Base plate for historic trams, suitable for components from the Mix & Match oldtimer catalog, according to illustration, color may vary.</i>		
OLD-103-A	€ 4,00	

Chassis / Chassis

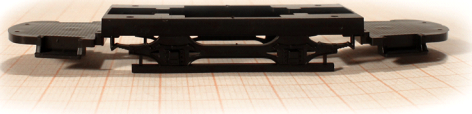
Oldtimer Straßenbahn Bodenplatte 103-C		
Bodenplatte für historische Straßenbahnen, passend zu Bauteilen aus dem Mix&Match Oldtimer-Katalog, gemäß Abbildung, Farbe kann abweichen.		
Vintage tram Base plate 103-C		
<i>Base plate for historic trams, suitable for components from the Mix & Match oldtimer catalog, according to illustration, color may vary.</i>		
OLD-103-C	€ 4,00	

Oldtimer Straßenbahn Bodenplatte 103-D		
Bodenplatte für historische Straßenbahnen, passend zu Bauteilen aus dem Mix&Match Oldtimer-Katalog, gemäß Abbildung, Farbe kann abweichen.		
Vintage tram Base plate 103-D		
<i>Base plate for historic trams, suitable for components from the Mix & Match oldtimer catalog, according to illustration, color may vary.</i>		
OLD-103-D	€ 4,00	

Oldtimer Straßenbahn Bodenplatte 104-C		
Bodenplatte für historische Straßenbahnen, passend zu Bauteilen aus dem Mix&Match Oldtimer-Katalog, gemäß Abbildung, Farbe kann abweichen.		
Vintage tram Base plate 104-C		
<i>Base plate for historic trams, suitable for components from the Mix & Match oldtimer catalog, according to illustration, color may vary.</i>		
OLD-104-C	€ 4,00	

		
OLD-104-D	€ 4,00	

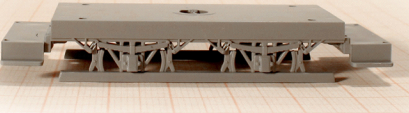
Oldtimer Straßenbahn Bodenplatte 105-B		
Bodenplatte für historische Straßenbahnen, passend zu Bauteilen aus dem Mix&Match Oldtimer-Katalog, gemäß Abbildung, Farbe kann abweichen.		
Vintage tram Base plate 105-B		
<i>Base plate for historic trams, suitable for components from the Mix & Match oldtimer catalog, according to illustration, color may vary.</i>		
OLD-105-B	€ 4,00	

Chassis / Chassis

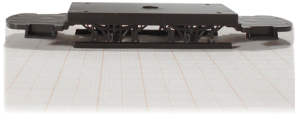
Oldtimer Straßenbahn Bodenplatte 105-D		
Bodenplatte für historische Straßenbahnen, passend zu Bauteilen aus dem Mix&Match Oldtimer-Katalog, gemäß Abbildung, Farbe kann abweichen.		
Vintage tram Base plate 105-D		
<i>Base plate for historic trams, suitable for components from the Mix & Match oldtimer catalog, according to illustration, color may vary.</i>		
OLD-105-D	€ 4,00	

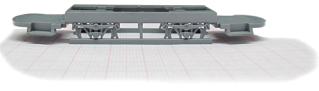
Oldtimer Straßenbahn Bodenplatte 106-C		
Bodenplatte für historische Straßenbahnen, passend zu Bauteilen aus dem Mix&Match Oldtimer-Katalog, gemäß Abbildung, Farbe kann abweichen.		
Vintage tram Base plate 106-C		
<i>Base plate for historic trams, suitable for components from the Mix & Match oldtimer catalog, according to illustration, color may vary.</i>		
OLD-106-C	€ 4,00	

Oldtimer Straßenbahn Bodenplatte 106-D		
Bodenplatte für historische Straßenbahnen, passend zu Bauteilen aus dem Mix&Match Oldtimer-Katalog, gemäß Abbildung, Farbe kann abweichen.		
Vintage tram Base plate 106-D		
<i>Base plate for historic trams, suitable for components from the Mix & Match oldtimer catalog, according to illustration, color may vary.</i>		
OLD-106-D	€ 4,00	

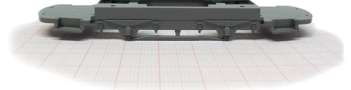
Oldtimer Straßenbahn Bodenplatte 107-A		
Bodenplatte für historische Straßenbahnen, passend zu Bauteilen aus dem Mix&Match Oldtimer-Katalog, gemäß Abbildung, Farbe kann abweichen.		
Vintage tram Base plate 107-A		
<i>Base plate for historic trams, suitable for components from the Mix & Match oldtimer catalog, according to illustration, color may vary.</i>		
OLD-107-A	€ 4,00	

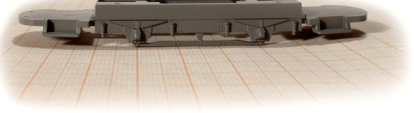
		
OLD-107-C	€ 4,00	

Chassis / Chassis

Oldtimer Straßenbahn Bodenplatte 117-A		
Bodenplatte für historische Straßenbahnen, passend zu Bauteilen aus dem Mix&Match Oldtimer-Katalog, gemäß Abbildung, Farbe kann abweichen.		
Vintage tram Base plate 117-A		
<i>Base plate for historic trams, suitable for components from the Mix & Match oldtimer catalog, according to illustration, color may vary.</i>		
OLD-117-A	€ 4,00	

Fahrerstand / Driver's Cabin

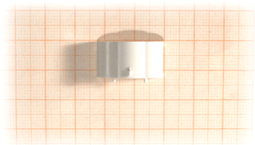
Oldtimer Straßenbahn Front 401-A		
Front für historische Straßenbahnen, passend zu Bauteilen aus dem Mix&Match Oldtimer-Katalog, gemäß Abbildung, Farbe kann abweichen.		
Vintage tram front 401-A		
<i>front for historic trams, suitable for components from the Mix & Match oldtimer catalog, according to illustration, color may vary.</i>		
OLD-401-A	€ 3,00	

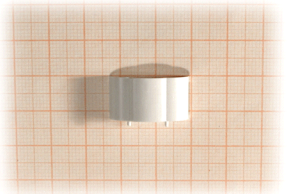
Oldtimer Straßenbahn Front 402-A		
Front für historische Straßenbahnen, passend zu Bauteilen aus dem Mix&Match Oldtimer-Katalog, gemäß Abbildung, Farbe kann abweichen.		
Vintage tram front 402-A		
<i>front for historic trams, suitable for components from the Mix & Match oldtimer catalog, according to illustration, color may vary.</i>		
OLD-402-A	€ 3,00	

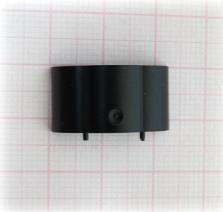
Oldtimer Straßenbahn Front 403-A		
Front für historische Straßenbahnen, passend zu Bauteilen aus dem Mix&Match Oldtimer-Katalog, gemäß Abbildung, Farbe kann abweichen.		
Vintage tram front 403-A		
<i>front for historic trams, suitable for components from the Mix & Match oldtimer catalog, according to illustration, color may vary.</i>		
OLD-403-A	€ 3,00	

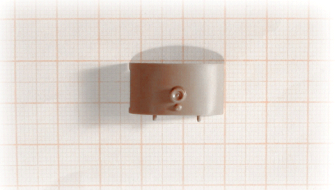
Oldtimer Straßenbahn Front 404-A		
Front für historische Straßenbahnen, passend zu Bauteilen aus dem Mix&Match Oldtimer-Katalog, gemäß Abbildung, Farbe kann abweichen.		
Vintage tram front 404-A		
<i>front for historic trams, suitable for components from the Mix & Match oldtimer catalog, according to illustration, color may vary.</i>		
OLD-404-A	€ 3,00	

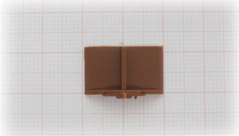
Oldtimer Straßenbahn Fahrerstand 405-A		
Fahrerstand für historische Straßenbahnen, passend zu Bauteilen aus dem Mix&Match Oldtimer-Katalog, gemäß Abbildung, Farbe kann abweichen.		
Vintage tram car roof 405-A		
<i>Driver's cab for historic trams, suitable for components from the Mix & Match oldtimer catalog, according to illustration, color may vary.</i>		
OLD-405-A	€ 3,00	

Fahrerstand / Driver's Cabin

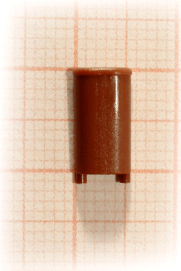
Oldtimer Straßenbahn Fahrschalter 406-A		
Fahrschalter für historische Straßenbahnen, passend zu Bauteilen aus dem Mix&Match Oldtimer-Katalog, gemäß Abbildung, Farbe kann abweichen.		
Vintage tram drive switch 406-A		
<i>drive switch for historic trams, suitable for components from the Mix & Match oldtimer catalog, according to illustration, color may vary.</i>		
OLD-406-A	€ 1,00	

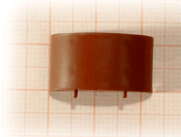
Oldtimer Straßenbahn Front 407-A		
Front für historische Straßenbahnen, passend zu Bauteilen aus dem Mix&Match Oldtimer-Katalog, gemäß Abbildung, Farbe kann abweichen.		
Vintage tram front 407-A		
<i>front for historic trams, suitable for components from the Mix & Match oldtimer catalog, according to illustration, color may vary.</i>		
OLD-407-A	€ 1,00	

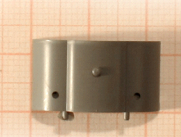
Oldtimer Straßenbahn Front 409-A		
Front für historische Straßenbahnen, passend zu Bauteilen aus dem Mix&Match Oldtimer-Katalog, gemäß Abbildung, Farbe kann abweichen.		
Vintage tram car front 409-A		
<i>front for historic trams, suitable for components from the Mix & Match oldtimer catalog, according to illustration, color may vary.</i>		
OLD-409-A	€ 3,00	

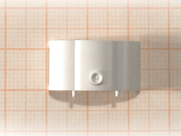
Oldtimer Straßenbahn Front 412-A		
Front für historische Straßenbahnen, passend zu Bauteilen aus dem Mix&Match Oldtimer-Katalog, gemäß Abbildung, Farbe kann abweichen.		
Vintage tram car front 412-A		
<i>front for historic trams, suitable for components from the Mix & Match oldtimer catalog, according to illustration, color may vary.</i>		
OLD-412-A	€ 3,00	

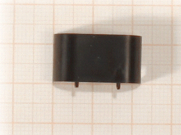
Oldtimer Straßenbahn Front 413-A		
Front für historische Straßenbahnen, passend zu Bauteilen aus dem Mix&Match Oldtimer-Katalog, gemäß Abbildung, Farbe kann abweichen.		
Vintage tram car front 413-A		
<i>front for historic trams, suitable for components from the Mix & Match oldtimer catalog, according to illustration, color may vary.</i>		
OLD-413-A	€ 3,00	

Fahrerstand / *Driver's Cabin*

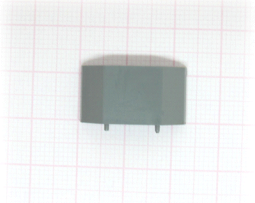
Oldtimer Straßenbahn Front 414-A		
Front für historische Straßenbahnen, passend zu Bauteilen aus dem Mix&Match Oldtimer-Katalog, gemäß Abbildung, Farbe kann abweichen.		
Vintage tram car front 414-A		
<i>front for historic trams, suitable for components from the Mix & Match oldtimer catalog, according to illustration, color may vary.</i>		
OLD-414-A	€ 3,00	

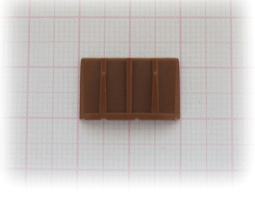
Oldtimer Straßenbahn Fahrerstand 420-A		
Fahrerstand für historische Straßenbahnen, passend zu Bauteilen aus dem Mix&Match Oldtimer-Katalog, gemäß Abbildung, Farbe kann abweichen.		
Vintage tram car driver's cab 420-A		
<i>Driver's cab for historic trams, suitable for components from the Mix & Match oldtimer catalog, according to illustration, color may vary.</i>		
OLD-420-A	€ 3,00	

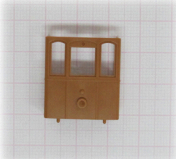
Oldtimer Straßenbahn Front 421-A		
Fahrerstand für historische Straßenbahnen, passend zu Bauteilen aus dem Mix&Match Oldtimer-Katalog, gemäß Abbildung, Farbe kann abweichen.		
Vintage tram car driver's cab 421-A		
<i>front for historic trams, suitable for components from the Mix & Match oldtimer catalog, according to illustration, color may vary.</i>		
OLD-421-A	€ 3,00	

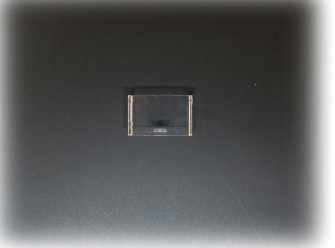
Oldtimer Straßenbahn Fenstereinsatz 604-A		
Fenstereinsatz für historische Straßenbahnen, passend zu Bauteilen aus dem Mix&Match Oldtimer-Katalog, gemäß Abbildung, Farbe kann abweichen.		
Vintage tram window inster 604-A		
<i>window insert for historic trams, suitable for components from the Mix & Match oldtimer catalog, according to illustration, color may vary.</i>		
OLD-604-A	€ 3,00	

Oldtimer Straßenbahn Frontfenster 606-A		
Frontfenster für historische Straßenbahnen, passend zu Bauteilen aus dem Mix&Match Oldtimer-Katalog, gemäß Abbildung, Farbe kann abweichen.		
Vintage tram window front 606-A		
<i>window front for historic trams, suitable for components from the Mix & Match oldtimer catalog, according to illustration, color may vary.</i>		
OLD-606-A	€ 3,00	

Fahrerstand / Driver's Cabin

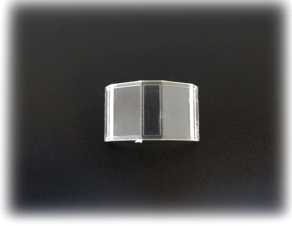
Oldtimer Straßenbahn Frontfenster 607-A		
Fahrerstand für historische Straßenbahnen, passend zu Bauteilen aus dem Mix&Match Oldtimer-Katalog, gemäß Abbildung, Farbe kann abweichen.		
Vintage tram car window front 607-A		
<i>Driver's cab for historic trams, suitable for components from the Mix & Match oldtimer catalog, according to illustration, color may vary.</i>		
OLD-607-A	€ 3,00	

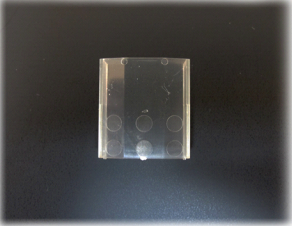
Oldtimer Straßenbahn Frontfenstereinsatz 608-A		
Frontfenstereinsatz für historische Straßenbahnen, passend zu Bauteilen aus dem Mix&Match Oldtimer-Katalog, gemäß Abbildung, Farbe kann abweichen.		
Vintage tram window front 608-A		
<i>window front for historic trams, suitable for components from the Mix & Match oldtimer catalog, according to illustration, color may vary.</i>		
OLD-608-A	€ 3,00	

Oldtimer Straßenbahn Frontfenster 609-A		
Frontfenster für historische Straßenbahnen, passend zu Bauteilen aus dem Mix&Match Oldtimer-Katalog, gemäß Abbildung, Farbe kann abweichen.		
Vintage tram window front 609-A		
<i>windwo front for historic trams, suitable for components from the Mix & Match oldtimer catalog, according to illustration, color may vary.</i>		
OLD-609-A	€ 3,00	

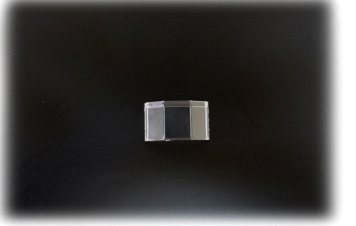
Oldtimer Straßenbahn Frontfenster 610-A		
Frontfenster für historische Straßenbahnen, passend zu Bauteilen aus dem Mix&Match Oldtimer-Katalog, gemäß Abbildung, Farbe kann abweichen.		
Vintage tram windwo front 610-A		
<i>window front for historic trams, suitable for components from the Mix & Match oldtimer catalog, according to illustration, color may vary.</i>		
OLD-610-A	€ 3,00	

Kleinteile / Additional Parts

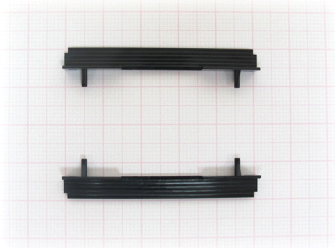
Oldtimer Straßenbahn Sitzbank 501-A		
Sitzbank (Triebwagen) für historische Straßenbahnen, passend zu Bauteilen aus dem Mix&Match Oldtimer-Katalog, gemäß Abbildung, Farbe kann abweichen.		
Vintage tram bench 501-A		
<i>Bench (railcar) for historic trams, suitable for components from the Mix & Match oldtimer catalog, according to illustration, color may vary.</i>		
OLD-501-A	€ 3,00	

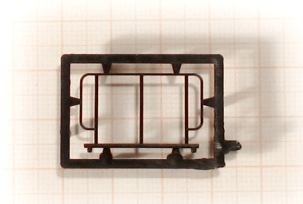
Oldtimer Straßenbahn Geländerhalter 502-A		
Geländerhalter für historische Straßenbahnen, passend zu Bauteilen aus dem Mix&Match Oldtimer-Katalog, gemäß Abbildung, Farbe kann abweichen.		
Vintage tram railing holder 502-A		
<i>railing holder for historic trams, suitable for components from the Mix & Match oldtimer catalog, according to illustration, color may vary.</i>		
OLD-502-A	€ 1,00	

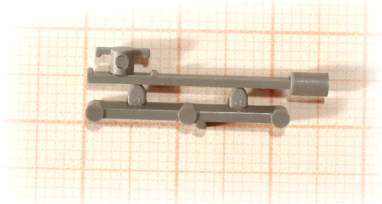
Oldtimer Straßenbahn Zubehör 503-A		
Zubehör für historische Straßenbahnen, passend zu Bauteilen aus dem Mix&Match Oldtimer-Katalog, gemäß Abbildung, Farbe kann abweichen.		
Vintage tram accessories 503-A		
<i>accessories for historic trams, suitable for components from the Mix & Match oldtimer catalog, according to illustration, color may vary.</i>		
OLD-503-A	€ 1,00	

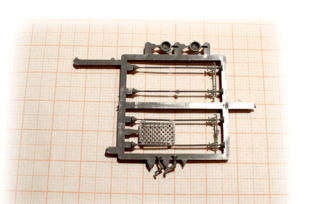
Oldtimer Straßenbahn Kunststoffgitter 504-A		
Kunststoffgitter für historische Straßenbahnen, passend zu Bauteilen aus dem Mix&Match Oldtimer-Katalog, gemäß Abbildung, Farbe kann abweichen.		
Vintage tram plastic grille 504-A		
<i>plastic grille for historic trams, suitable for components from the Mix & Match oldtimer catalog, according to illustration, color may vary.</i>		
OLD-504-A	€ 3,00	

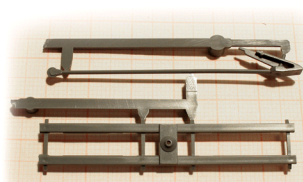
Oldtimer Straßenbahn Stangenstromabn. 505-A		
Stangenstromabnehmer für historische Straßenbahnen, passend zu Bauteilen aus dem Mix&Match Oldtimer-Katalog, gemäß Abbildung, Farbe kann abweichen.		
Vintage tram pantographs 505-A		
<i>pantographs for historic trams, suitable for components from the Mix & Match oldtimer catalog, according to illustration, color may vary.</i>		
OLD-505-A	€ 1,00	

Kleinteile / Additional Parts

Oldtimer Straßenbahn Kupplung "Kurz"	
Kupplung (kurz) für historische Straßenbahnen, passend zu Bauteilen aus dem Mix&Match Oldtimer-Katalog, gemäß Abbildung, Farbe kann abweichen.	
Vintage tram coupling "Short" <i>coupling (short) for historic trams, suitable for components from the Mix & Match oldtimer catalog, according to illustration, color may vary.</i>	
OLD-507-A	€ 1,00
Oldtimer Straßenbahn Kupplung "Lang"	
Kupplung (lang) für historische Straßenbahnen, passend zu Bauteilen aus dem Mix&Match Oldtimer-Katalog, gemäß Abbildung, Farbe kann abweichen.	
Vintage tram coupling "Long" <i>Long coupling for historic trams, suitable for components from the Mix & Match oldtimer catalog, according to illustration, color may vary.</i>	
OLD-508-A	€ 1,00
Oldtimer Straßenbahn Kupplung 511-A	
Kupplung (breit) für historische Straßenbahnen, passend zu Bauteilen aus dem Mix&Match Oldtimer-Katalog, gemäß Abbildung, Farbe kann abweichen.	
Vintage tram coupling 511-A <i>coupling (wide) for historic trams, suitable for components from the Mix & Match oldtimer catalog, according to illustration, color may vary.</i>	
OLD-511-A	€ 1,00
Oldtimer Straßenbahn Zubehör 512-A	
Zubehör für historische Straßenbahnen, passend zu Bauteilen aus dem Mix&Match Oldtimer-Katalog, gemäß Abbildung, Farbe kann abweichen.	
Vintage tram equipment 512-A <i>equipment for historic trams, suitable for components from the Mix & Match oldtimer catalog, according to illustration, color may vary.</i>	
OLD-512-A	€ 3,00
Oldtimer Straßenbahn Leiste 513-A	
Leiste für historische Straßenbahnen, passend zu Bauteilen aus dem Mix&Match Oldtimer-Katalog OLD-304-A, OLD-341-A, gemäß Abbildung, Farbe kann abweichen.	
Vintage tram strip 513-A <i>strip for historic trams, suitable for components from the Mix & Match oldtimer catalog, OLD-304-A, OLD-341-A according to illustration, color may vary.</i>	
OLD-513-A	€ 1,00

Kleinteile / Additional Parts

Oldtimer Wappen Straßenbahn 515-A		
Wappen für historische Straßenbahnen, passend zu Bauteilen aus dem Mix&Match Oldtimer-Katalog, gemäß Abbildung, Farbe kann abweichen.		
Vintage tram blazon 515-A		
<i>blazon for historic trams, suitable for components from the Mix & Match oldtimer catalog, according to illustration, color may vary.</i>		
OLD-515-A	€ 1,00	
Oldtimer Straßenbahn Wappen 516-A		
Wappen für historische Straßenbahnen, passend zu Bauteilen aus dem Mix&Match Oldtimer-Katalog, gemäß Abbildung, Farbe kann abweichen.		
Vintage tram blazon 516-A		
<i>blazon for historic trams, suitable for components from the Mix & Match oldtimer catalog, according to illustration, color may vary.</i>		
OLD-516-A	€ 1,00	
Oldtimer Straßenbahn Zurüstteile 517-A		
für historische Straßenbahnen, passend zu Bauteilen aus dem Mix&Match Oldtimer-Katalog, gemäß Abbildung, Farbe kann abweichen.		
Vintage tram scaffolding parts 517-A		
<i>for historic trams, suitable for components from the Mix & Match oldtimer catalog, according to illustration, color may vary.</i>		
OLD-517-A	€ 1,00	
Oldtimer Straßenbahn Sitzbank 518-A		
Bank (Beiwagen) für historische Straßenbahnen, passend zu Bauteilen aus dem Mix&Match Oldtimer-Katalog, gemäß Abbildung, Farbe kann abweichen.		
Vintage tram bench 518-A		
<i>Bench (sidecar) for historic trams, suitable for components from the Mix & Match oldtimer catalog, according to illustration, color may vary.</i>		
OLD-518-A	€ 3,00	
Oldtimer Straßenbahn Linienschild 520-A		
Linienschild für historische Straßenbahnen, passend zu Bauteilen aus dem Mix&Match Oldtimer-Katalog, gemäß Abbildung, Farbe kann abweichen.		
Vintage tram line sign 520-A		
<i>line sign for historic trams, suitable for components from the Mix & Match oldtimer catalog, according to illustration, color may vary.</i>		
OLD-520-A	€ 1,00	

Kleinteile / *Additional Parts*

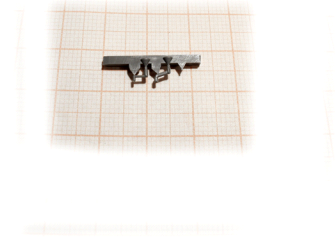
Oldtimer Straßenbahn Zubehör 522-A		
Zubehör für historische Straßenbahnen, passend zu Bauteilen aus dem Mix&Match Oldtimer-Katalog, gemäß Abbildung, Farbe kann abweichen.		
Vintage tram equipment 522-A		
<i>equipment for historic trams, suitable for components from the Mix & Match oldtimer catalog, according to illustration, color may vary.</i>		
OLD-522-A	€ 1,00	

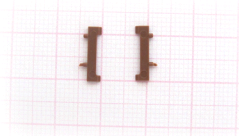
Oldtimer Straßenbahn Zubehör 524-A		
Zubehör für historische Straßenbahnen, passend zu Bauteilen aus dem Mix&Match Oldtimer-Katalog, gemäß Abbildung, Farbe kann abweichen.		
Vintage tram equipment 524-A		
<i>equipment for historic trams, suitable for components from the Mix & Match oldtimer catalog, according to illustration, color may vary.</i>		
OLD-524-A	€ 1,00	

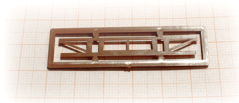
Oldtimer Straßenbahn Fahrwerksblende 525-A		
Fahrwerksblende für historische Straßenbahnen, passend zu Bauteilen aus dem Mix&Match Oldtimer-Katalog, gemäß Abbildung, Farbe kann abweichen.		
Vintage tram drive bezel 525-A		
<i>drive bezel for historic trams, suitable for components from the Mix & Match oldtimer catalog, according to illustration, color may vary.</i>		
OLD-525-A	€ 1,00	

Oldtimer Straßenbahn Zubehör 526-A		
Zubehör für historische Straßenbahnen, passend zu Bauteilen aus dem Mix&Match Oldtimer-Katalog, gemäß Abbildung, Farbe kann abweichen.		
Vintage tram equipment 526-A		
<i>equipment for historic trams, suitable for components from the Mix & Match oldtimer catalog, according to illustration, color may vary.</i>		
OLD-526-A	€ 1,00	

Oldtimer Straßenbahn Stosstange 527-A		
Stosstange für historische Straßenbahnen, passend zu Bauteilen aus dem Mix&Match Oldtimer-Katalog, gemäß Abbildung, Farbe kann abweichen.		
Vintage tram bumper 527-A		
<i>bumper for historic trams, suitable for components from the Mix & Match oldtimer catalog, according to illustration, color may vary.</i>		
OLD-527-A	€ 1,00	

Kleinteile / Additional Parts

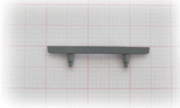
Oldtimer Straßenbahn Bahnräumer 528-A		
Bahnräumer für historische Straßenbahnen, passend zu Bauteilen aus dem Mix&Match Oldtimer-Katalog, gemäß Abbildung, Farbe kann abweichen.		
Vintage tram track clearers 528-A		
<i>track clearers for historic trams, suitable for components from the Mix & Match oldtimer catalog, according to illustration, color may vary.</i>		
OLD-528-A	€ 1,00	

Oldtimer Straßenbahn Schild 529-A		
Schild für historische Straßenbahnen, passend zu Bauteilen aus dem Mix&Match Oldtimer-Katalog, gemäß Abbildung, Farbe kann abweichen.		
Vintage tram sign 529-A		
<i>sign for historic trams, suitable for components from the Mix & Match oldtimer catalog, according to illustration, color may vary.</i>		
OLD-529-A	€ 1,00	

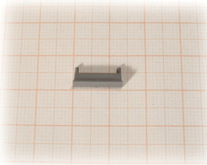
Oldtimer Straßenbahn Kupplungsauflage 530-A		
Kupplungsauflage für historische Straßenbahnen, passend zu Bauteilen aus dem Mix&Match Oldtimer-Katalog, gemäß Abbildung, Farbe kann abweichen.		
Vintage tram clutch linings 530-A		
<i>clutch linings for historic trams, suitable for components from the Mix & Match oldtimer catalog, according to illustration, color may vary.</i>		
OLD-530-A	€ 1,00	

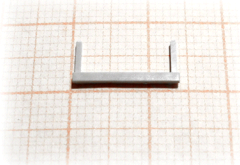
Oldtimer Straßenbahn Kupplungsauflage 531-A		
Kupplungsauflage für historische Straßenbahnen, passend zu Bauteilen aus dem Mix&Match Oldtimer-Katalog, gemäß Abbildung, Farbe kann abweichen.		
Vintage tram clutch linings 531-A		
<i>clutch linings for historic trams, suitable for components from the Mix & Match oldtimer catalog, according to illustration, color may vary.</i>		
OLD-531-A	€ 1,00	

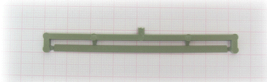
Oldtimer Straßenbahn Zubehör 532-A		
Zubehör für historische Straßenbahnen, passend zu Bauteilen aus dem Mix&Match Oldtimer-Katalog, gemäß Abbildung, Farbe kann abweichen.		
Vintage tram equipment 532-A		
<i>equipment for historic trams, suitable for components from the Mix & Match oldtimer catalog, according to illustration, color may vary.</i>		
OLD-532-A	€ 1,00	

Kleinteile / *Additional Parts*

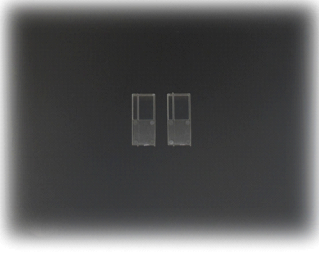
Oldtimer Straßenbahn Tür 602-A		
Tür für historische Straßenbahnen, passend zu Bauteilen aus dem Mix&Match Oldtimer-Katalog, gemäß Abbildung, Farbe kann abweichen.		
Vintage tram door 602-A		
<i>Door for historic trams, suitable for components from the Mix & Match oldtimer catalog, according to illustration, color may vary.</i>		
OLD-602-A	€ 1,00	

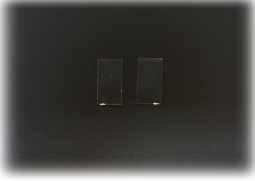
Oldtimer Straßenbahn Türenster 603-A		
Türenster (passend zu OLD-702-A) für historische Straßenbahnen, passend zu Bauteilen aus dem Mix&Match Oldtimer-Katalog, gemäß Abbildung, Farbe kann abweichen.		
Vintage tram door window 603-A		
<i>door window (suitable for OLD-702)for historic trams, suitable for components from the Mix & Match oldtimer catalog, according to illustration, color may vary.</i>		
OLD-603-A	€ 1,00	

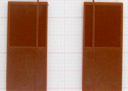
Oldtimer Straßenbahn Tür 701-A		
Tür für historische Straßenbahnen, passend zu Bauteilen aus dem Mix&Match Oldtimer-Katalog, gemäß Abbildung, Farbe kann abweichen.		
Vintage tram door 701-A		
<i>Door for historic trams, suitable for components from the Mix & Match oldtimer catalog, according to illustration, color may vary.</i>		
OLD-701-A	€ 1,00	

Oldtimer Straßenbahn Tür 702-A		
Tür (passend für OLD-603-A) für historische Straßenbahnen, passend zu Bauteilen aus dem Mix&Match Oldtimer-Katalog, gemäß Abbildung, Farbe kann abweichen.		
Vintage tram door 702-A		
<i>door (suitable for OLD-603-A) for historic trams, suitable for components from the Mix & Match oldtimer catalog, according to illustration, color may vary.</i>		
OLD-702-A	€ 1,00	

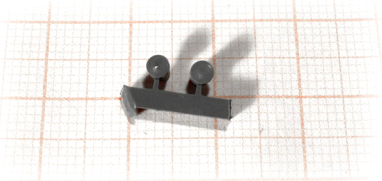
Oldtimer Straßenbahn Zubehör 801-A		
Zubehör für historische Straßenbahnen, passend zu Bauteilen aus dem Mix&Match Oldtimer-Katalog, gemäß Abbildung, Farbe kann abweichen.		
Vintage tram equipment 801-A		
<i>equipment for historic trams, suitable for components from the Mix & Match oldtimer catalog, according to illustration, color may vary.</i>		
OLD-801-A	€ 1,00	

Kleinteile / *Additional Parts*

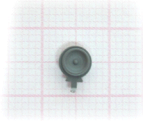
Oldtimer Straßenbahn Zubehör 802-A		
Zubehör für historische Straßenbahnen, passend zu Bauteilen aus dem Mix&Match Oldtimer-Katalog, gemäß Abbildung, Farbe kann abweichen.		
Vintage tram equipment 802-A		
<i>equipment for historic trams, suitable for components from the Mix & Match oldtimer catalog, according to illustration, color may vary.</i>		
OLD-802-A	€ 1,00	

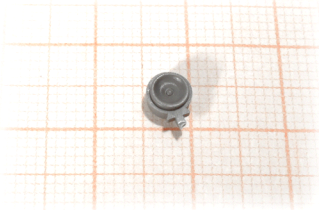
Oldtimer Straßenbahn Zubehör 803-A		
Zubehör für historische Straßenbahnen, passend zu Bauteilen aus dem Mix&Match Oldtimer-Katalog, gemäß Abbildung, Farbe kann abweichen.		
Vintage tram equipment 803-A		
<i>equipment for historic trams, suitable for components from the Mix & Match oldtimer catalog, according to illustration, color may vary.</i>		
OLD-803-A	€ 1,00	

Pantografen / *Pantographs*

Breiter Scherenbügel C1		
Breiter Scherenbügel C1		
Wide pantograph C1		
<i>Wide pantograph C1</i>		
PAN-SC1	€ 13,00	

Scherenbügel mit Doppelschleifstück, brüniert		
Scherenbügel mit Doppelschleifstück, brüniert		
Pantograph with double slider		
<i>Pantograph with double slider</i>		
PAN-SDS	€ 13,00	

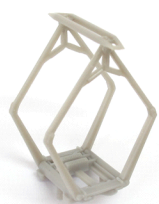
Kunststoff-Scherenbügel, grau		
Kunststoff-Scherenbügel, grau		
Plastic pantograph, grey		
<i>Plastic pantograph, grey</i>		
PAN-SKS	€ 7,00	

Scherenbügel, Metall brüniert		
Scherenbügel, Metall brüniert		
Pantograph, metal, blackened		
<i>Pantograph, metal, blackened</i>		
PAN-SMU	€ 13,00	

Einholmstromabnehmer mit breiter Palette		
Einholmstromabnehmer neuer Standard mit 20,5mm Palette.		
One-arm pantograph, with wide palette		
<i>One-arm pantograph, new standard, 20,5 mm palette.</i>		
PAN-E01	€ 13,00	

Pantografen / Pantographs

Einholmbügel neuer Standard	
Einholmbügel geschlossen, neuer Standard mit 20,3 mm Palette.	
One-arm pantograph ,closed, new standard	
<i>One-arm pantograph, closed, new standard, with 20,3mm palette</i>	
PAN-E02	€ 13,00



Einholmstromabnehmer, rot	
Einholmstromabnehmer	
One-arm pantograph, red	
<i>One-arm pantograph</i>	
PAN-E03	€ 13,00



Einholmbügel, breite offene Palette	
Einholmbügel, breites, offenes Schleifstück; auch PAN-E04	
One-arm pantograph, open end palette	
<i>One-arm pantograph, blackened, silver nickel, open ends</i>	
PAN-E04	€ 13,00



Einholm-Stromabnehmer DOHA, Spur N	
Einholm-Stromabnehmer DOHA, Spur N	
One-arm pantograph, DOHA, N-gauge	
<i>One-arm pantograph, DOHA, N-gauge</i>	
PAN-EDO	€ 13,00



Einholm-Stromabnehmer Kunststoff, grau	
Einholm-Stromabnehmer Kunststoff, grau	
One-arm pantograph, plastic, grey	
<i>One-arm pantograph, plastic, grey</i>	
PAN-EKS	€ 8,00



Pantografen / *Pantographs*

Stromabnehmer "Himmelstreppe"	 
Stromabnehmer, brüniert, "Himmelstreppe"	
One-arm pantograph "Himmelstreppe"	
<i>One-arm pantograph, blackened, silver nickel, "Himmelstreppe"</i>	
PAN-HTP	€ 13,00

Lyrabügel, Metall, lackiert	 
Lyrabügel, Metall, lackiert	
Bow collector, metal, painted	
<i>Bow collector, metal, painted</i>	
PAN-LYM	€ 13,00

Lyrabügel dunkelgrau	 
Lyrabügel für z.B. G-Wagen, Kunststoff dunkelgrau lackiert	
Bow collector, dark grey	
<i>Bow collector, dark grey, plastic, e.g. for G-type trams</i>	
PAN-DGR	€ 11,50

Lyrabügel grau	 
Lyrabügel für z.B. G-Wagen, Kunststoff grau	
Bow collector, grey	
<i>Bow collector, grey, plastic, e.g. for G-type trams</i>	
PAN-GRA	€ 10,50

Lyrabügel silber	 
Lyrabügel für z.B. G-Wagen, Kunststoff Silber lackiert	
Bow collector, plastic, painted silver	
<i>Bow collector, plastic, painted silver</i>	
PAN-SIL	€ 11,50

Pantografen / Pantographs

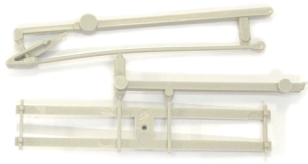
Stagen-Stromabnehmer m. Basis, hellgrau		
Lyrabügel für z.B. G-Wagen, Kunststoff dunkelgrau lackiert		
Bow collector, dark grey		
<i>Bow collector, dark grey, plastic, e.g for G-type trams</i>		
PAN-STA	€ 4,50	

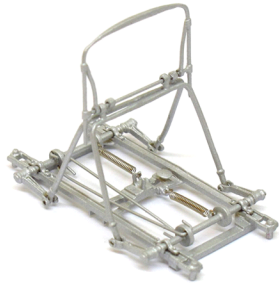



Pantograph, MzB 1099 Altbau, Siemens, silber, Ep. 1-2		
Pantograph, MzB 1099 Altbau, Siemens, silber, Ep. 1-2		
Pantograph, MzB 1099 Altbau, Siemens, silver, Ep. 1-2		
<i>Pantograph, MzB 1099 Altbau, Siemens, silver, Ep. 1-2</i>		
EHE0199	€ 66,00	

Pantograph, Siemens, rot, für MzB Ep3a		
Pantograph, Siemens, rot, für MzB Ep 3a, mit Schutzbügel		
Pantograph, Siemens, red, for MzB Ep 3a		
<i>Pantograph, Siemens, red, for MzB Ep 3a, with icycle protector</i>		
EHE0299	€ 66,00	

Pantograph, MzB 1099 Altbau, Doppelschere, rot, Ep.3		
Doppelscheren-Pantograph karminrot, für alle 1099 Loks mit Altbau -kasten.		
Pantograph, 1099 OLD style, karmin red, ep.3		
<i>Pantograph karmin red for all locos class 1099 with OLD style body. Doppelschere .</i>		
EHE0399	€ 66,00	

Pantograph, 1099 Neubau, karminrot, Ep.4		
Pantograph karminrot, für alle 1099 Loks mit Neubau-Kasten. Besonders feine Version wie von Fa. Stängl verwendet.		
Pantograph, 1099 new style, karmin red, ep.4		
<i>Pantograph karmin red for all locos class 1099 with new style body. Improved version as used by Stängl.</i>		
EHE0499	€ 37,00	

Pantografen / Pantographs

Pantograph, 1099 Neubau, verkehrsrot, Ep.5-6	 
Pantograph verkehrsrot, für alle 1099 Loks mit Neubau-Kasten. Besonders feine Version wie von Fa. Stängl verwendet.	
Pantograph,1099 new style, traffic red, ep.5-6	
<i>Pantograph traffic red for all locos class 1099 with new style body. Improved design as used by Stängl.</i>	
EHE0599	€ 37,00
Pantograph, 1099 Neubau, verkehrsrot, Ep. 4-6	 
Pantograph verkehrsrot, für alle 1099 Loks mit Neubau-kasten. Originalteil von Fa. ROCO	
Pantograph,1099 new style, traffic red, ep. 4-6	
<i>Pantograph traffic red for all locos class 1099 with new style body. Original ROCO part.</i>	
EHE0599-ROCO	€ 20,00

Antriebe / Drives

Varioantrieb H0, mit Vollrad, var. Achsabstand		
<p>Motor 12V=, Spur H0, 2 Achsen angetrieben, 4 Räder stromführend, kein Haftreifen, Achsabstand 23mm, 26mm oder 30,4mm , Rad-Durchmesser 9mm. Der Achsabstand kann einfach geändert werden!</p>		
<p>Vario-drive H0, solid wheels, wheelbase adjust. <i>Variable wheelbase. No tools required!</i> Voltage 12V=, gauge H0, 2 powered axles, 4 conducting axles, w/o traction tyres, wheelbase 23mm, 26mm or 30,4mm , wheel diameter 9mm. <i>The center distance can easily be changed!</i></p>		
ANT-VAR-H0	€ 45,00	

Varioantrieb H0m, mit Vollrad, var. Achsabstand		
<p>Motor 12V=, Spur H0m, 2 Achsen angetrieben, 4 Räder stromführend, kein Haftreifen, Achsabstand 23mm, 26mm oder 30,4mm Rad-Durchmesser 9mm. Der Achsabstand kann einfach geändert werden!</p>		
<p>Vario-drive H0m, solid wheels, wheelbase adjust. <i>Vario-drive H0m</i> <i>Variable wheelbase. No tools required!</i> Voltage 12V=, gauge H0m, 2 powered axles, 4 conducting axles, w/o traction tyres, wheelbase 23mm, 26mm or 30,4mm , wheel diameter 9mm.</p>		
ANT-VAR-H0M	€ 45,00	

Varioantrieb H0e, mit Vollrad, var. Achsabstand		
<p>Motor 12V=, Spur H0e, 2 Achsen angetrieben, 4 Räder stromführend, kein Haftreifen, Achsabstand 23mm, 26mm oder 30,4mm , Rad-Durchmesser 9mm. Der Achsabstand kann einfach geändert werden!</p>		
<p>Vario-drive H0e, solid wheels, wheelbase adjust. <i>Variable wheelbase. No tools required!</i> Voltage 12V=, gauge H0e, 2 powered axles, 4 conducting axles w/o traction tyres, wheelbase 23mm, 26mm or 30,4mm , wheel diameter 9mm. <i>The center distance can easily be changed!</i></p>		
ANT-VAR-H0E	€ 45,00	

Varioantrieb H0, mit Speichenrad, var. Achsstand		
<p>Varioantrieb mit Speichenrad. Der Achsabstand kann einfach geändert werden! Motor 12V=, Spur H0, 2 Achsen angetrieben, 4 Räder stromführend, kein Haftreifen, Achsabstand 23mm, 26mm oder 30,4mm, Rad-Durchmesser 9mm.</p>		
<p>vario-drive H0, spoked wheels, wheelbase adjust. <i>Drive with spoked wheels.</i> <i>Variable wheelbase. No tools required!</i> Voltage 12V=, gauge H0, 2 powered axles, 4 conducting axles, w/o traction tyres, wheelbase 23mm, 26mm or 30,4mm , wheel diameter 9mm.</p>		
ANT-VAR-H0-SP	€ 51,50	

Antriebe / Drives

Varioantrieb H0m, Speichenrad, var. Achsstand		
<p>Varioantrieb mit Speichenrad. Der Achsabstand kann einfach geändert werden! Motor 12V=, Spur H0m, 2 Achsen angetrieben, 4 Räder stromführend, kein Haftreifen, Achsabstand 23mm, 26mm oder 30,4mm, Rad-Durchmesser 9mm.</p>		
<p>vario-drive H0m, spoked wheels, wheelbase adjust.</p> <p><i>Drive with spoked wheels. Variable wheelbase. No tools required! Voltage 12V=, gauge H0m, 2 powered axles, 4 conducting axles, w/o traction tyres, wheelbase 23mm, 26mm or 30,4mm, wheel diameter 9mm.</i></p>		
ANT-VAR-H0M-SP	€ 51,50	

Varioantrieb H0e, Speichenrad, var. Achsstand		
<p>Varioantrieb mit Speichenrad. Der Achsabstand kann einfach geändert werden! Motor 12V=, Spur H0e, 2 Achsen angetrieben, 4 Räder stromführend, kein Haftreifen, Achsabstand 23mm, 26mm oder 30,4mm, Rad-Durchmesser 9mm.</p>		
<p>vario-drive H0e, spoked wheels, wheelbase adjust.</p> <p><i>Drive with spoked wheels. Variable wheelbase. No tools required! Voltage 12V=, gauge H0e, 2 powered axles, 4 conducting axles, w/o traction tyres, wheelbase 23mm, 26mm or 30,4mm, wheel diameter 9mm.</i></p>		
ANT-VAR-H0E-SP	€ 51,50	

Varioantrieb V2 H0, Vollrad, var. Achsstand		
<p>Varioantrieb mit Glockenankermotor. Der Achsabstand kann einfach geändert werden! Motor 12V=, Spur H0 2 Achsen angetrieben, 4 Räder stromführend, kein Haftreifen Achsabstand 23mm, 26mm oder 30,4mm Rad-Durchmesser 9mm.</p>		
<p>Vario-drive V2 H0, solid wheels, wheelbase adj.</p> <p><i>Drive with solid wheels. Variable wheelbase: 23.1mm, 26.8mm and 30.5mm variabel. No tools required! coreless Motor, Voltage 12V=, gauge H0, 2 powered axles, 4 conducting axles, w/o traction tyres, wheelbase 23mm, 26mm or 30,4mm, wheel diameter 9mm.</i></p>		
ANT-VAR-V2-H0	€ 66,00	

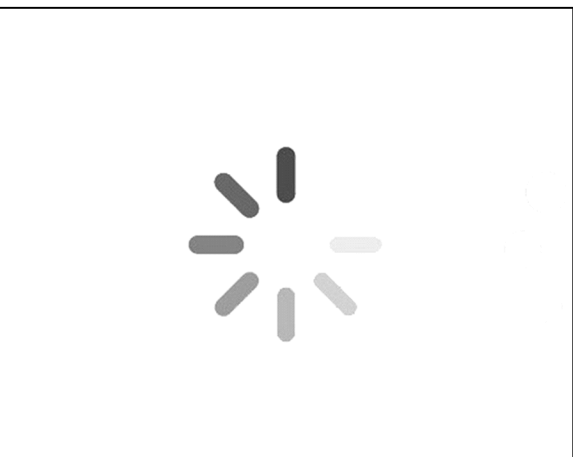
Varioantrieb V2 H0e, Vollrad, var. Achsstand		
<p>Varioantrieb mit Glockenankermotor. Der Achsabstand kann einfach geändert werden! Motor 12V=, Spur H0e 2 Achsen angetrieben, 4 Räder stromführend, kein Haftreifen Achsabstand 23mm, 26mm oder 30,4mm Rad-Durchmesser 9mm.</p>		
<p>Vario-drive V2 H0m, solid wheels, wh.base adj.</p> <p><i>Drive with solid wheels. Variable wheelbase. No tools required! coreless Motor, Voltage 12V=, gauge H0e, 2 powered axles, 4 conducting axles, w/o traction tyres, wheelbase 23mm, 26mm or 30,4mm, wheel diameter 9mm.</i></p>		
ANT-VAR-V2-H0E	€ 66,00	

Antriebe / Drives

Varioantrieb V2 H0m, Vollrad, var. Achsst.	
Varioantrieb mit Glockenankermotor. Der Achsabstand kann einfach geändert werden! Motor 12V=, Spur H0m 2 Achsen angetrieben, 4 Räder stromführend, kein Haftreifen Achsabstand 23mm, 26mm oder 30,4mm Rad-Durchmesser 9mm.	
Vario-drive V2 H0m, solid wheels, wheelbase adj.	
<i>Drive with solid wheels. Variable wheelbase. No tools required! coreless Motor, Voltage 12V=, gauge H0m, 2 powered axles, 4 conducting axles, w/o traction tyres, wheelbase 23mm, 26mm or 30,4mm, wheel diameter 9mm.</i>	
ANT-VAR-V2-H0M	€ 66,00

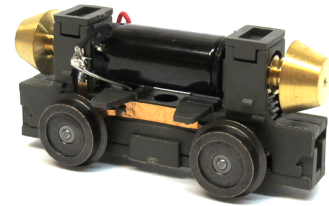

Kurzer Varioantrieb V3 H0, Vollrad, var. Achsstand	
Varioantrieb mit Glockenankermotor, ohne Schwungmassen. Der Achsabstand kann einfach geändert werden! Motor 12V=, Spur H0 2 Achsen angetrieben, 4 Räder stromführend, kein Haftreifen Achsabstand 23mm, 26mm oder 30,4mm Rad-Durchmesser 9mm.	
Short Vario-drive V3 H0, solid wheels, wheelbase adj.	
<i>Drive with solid wheels, without fly wheels. Variable wheelbase: 23.1mm, 26.8mm and 30.5mm variabel. No tools required! coreless Motor, Voltage 12V=, gauge H0, 2 powered axles, 4 conducting axles, w/o traction tyres, wheelbase 23mm, 26mm or 30,4mm, wheel diameter 9mm.</i>	
ANT-VAR-V3-H0	€ 66,00



Kurzer Varioantrieb V3 H0e, Vollrad, var. Achsstand	
Varioantrieb mit Glockenankermotor, ohne Schwungmassen. Der Achsabstand kann einfach geändert werden! Motor 12V=, Spur H0e 2 Achsen angetrieben, 4 Räder stromführend, kein Haftreifen Achsabstand 23mm, 26mm oder 30,4mm Rad-Durchmesser 9mm.	
Short Vario-drive V3 H0e, solid wheels, wh.base adj.	
<i>Drive with solid wheels, without fly wheels. Variable wheelbase: 23.1mm, 26.8mm and 30.5mm variabel. No tools required! coreless Motor, Voltage 12V=, gauge H0e, 2 powered axles, 4 conducting axles, w/o traction tyres, wheelbase 23mm, 26mm or 30,4mm, wheel diameter 9mm.</i>	
ANT-VAR-V3-H0E	€ 66,00



Kurzer Varioantrieb V3 H0m, Vollrad, var. Achsstand	
Varioantrieb mit Glockenankermotor, ohne Schwungmassen. Der Achsabstand kann einfach geändert werden! Motor 12V=, Spur H0m 2 Achsen angetrieben, 4 Räder stromführend, kein Haftreifen Achsabstand 23mm, 26mm oder 30,4mm Rad-Durchmesser 9mm.	
Short Vario-drive V3 H0m, solid wheels, wh.base adj.	
<i>Drive with solid wheels, without fly wheels. Variable wheelbase: 23.1mm, 26.8mm and 30.5mm variabel. No tools required! coreless Motor, Voltage 12V=, gauge H0m, 2 powered axles, 4 conducting axles, w/o traction tyres, wheelbase 23mm, 26mm or 30,4mm, wheel diameter 9mm.</i>	
ANT-VAR-V3-H0M	€ 66,00



Antriebe / Drives

Varioantrieb H0 Teilesatz	
Teilesatz mit Vollrad, Achsabstand 23mm, 26mm oder 30,4mm variabel Motor 12V=, Spur H0, 2 Achsen angetrieben, 4 Räder stromführend kein Haftreifen, Achsabstand 23mm, 26mm oder 30,4mm , Rad-Durchmesser 9mm. Der Achsabstand kann einfach geändert werden!	
Vario-drive H0 kit	
<i>Kit with solid wheels, wheelbase adjustable to 23mm, 26mm or 30,4mm</i> <i>Variable wheelbase. No tools required!</i> <i>Voltage 12V=, gauge H0, 2 powered axles, 4 conducting axles, w/o traction tyres, wheelbase 23mm, 26mm or 30,4mm , wheel diameter 9mm.</i> <i>The center distance can easily be changed!</i>	
ANT-VAR-H0-BS	€ 41,00

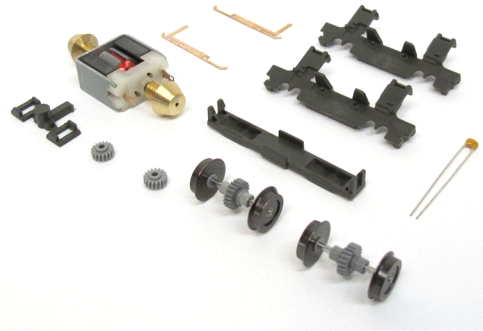

Varioantrieb H0e Teilesatz	
Teilesatz mit Vollrad, Achsabstand 23mm, 26mm oder 30,4mm variabel Motor 12V=, Spur H0e, 2 Achsen angetrieben, 4 Räder stromführend kein Haftreifen, Achsabstand 23mm, 26mm oder 30,4mm , Rad-Durchmesser 9mm. Der Achsabstand kann einfach geändert werden!	
Vario-drive H0e kit	
<i>Kit with solid wheels, wheelbase adjustable to 23mm, 26mm or 30,4mm</i> <i>Variable wheelbase. No tools required!</i> <i>Voltage 12V=, gauge H0e, 2 powered axles, 4 conducting axles, w/o traction tyres, wheelbase 23mm, 26mm or 30,4mm , wheel diameter 9mm.</i> <i>The center distance can easily be changed!</i>	
ANT-VAR-H0E-BS	€ 41,00

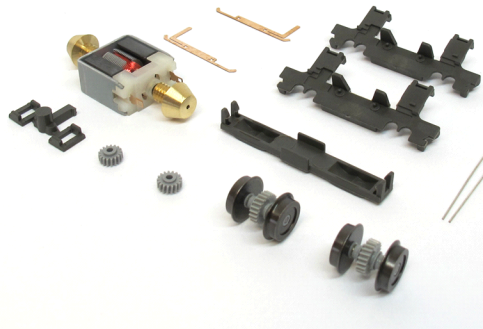

Varioantrieb H0m Teilesatz	
Teilesatz mit Vollrad, Achsabstand 23mm, 26mm oder 30,4mm variabel. Motor 12V=, Spur H0m, 2 Achsen angetrieben, 4 Räder stromführend, kein Haftreifen, Achsabstand 23mm, 26mm oder 30,4mm , Rad-Durchmesser 9mm. Der Achsabstand kann einfach geändert werden!	
Vario-drive H0 kit	
<i>Kit with solid wheels, wheelbase adjustable to 23mm, 26mm or 30,4mm</i> <i>Variable wheelbase. No tools required!</i> <i>Voltage 12V=, gauge H0m, 2 powered axles, 4 conducting axles, w/o traction tyres, wheelbase 23mm, 26mm or 30,4mm , wheel diameter 9mm.</i>	
ANT-VAR-H0M-BS	€ 41,00

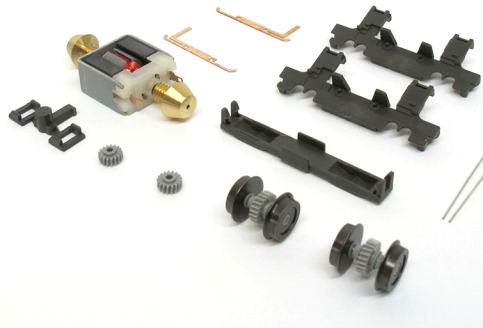

Antriebe / Drives

Varioantrieb H0, Vollrad, var. Achsst., Decoder	
Motor 12V=, Spur H0, 2 Achsen angetrieben, 4 Räder stromführend kein Haftreifen, Achsabstand 23mm, 26mm oder 30,4mm , Rad-Durchmesser 9mm. Digital: Zimo MX 623 Der Achsabstand kann einfach geändert werden!	
Vario-drive H0, solid wh., wh.b. adj., with DCC	
<i>Variable wheelbase. No tools required!</i> <i>Voltage 12V=, gauge H0, 2 powered axles, 4 conducting axles, w/o traction tyres, wheelbase 23mm, 26mm or 30,4mm , wheel diameter 9mm.</i> <i>DCC: Zimo MX 623</i> <i>The center distance can easily be changed!</i>	
ANT-VAR-H0-D	€ 89,00

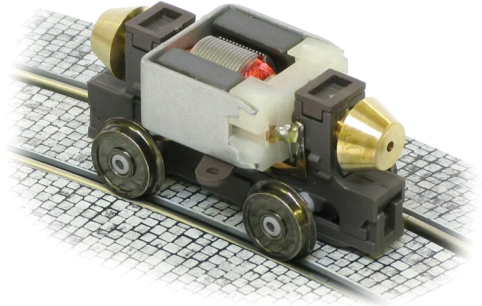

Komplette Teilesätze / Complete Sets

Wien Type M Triebwagen, Weißmodell, Bausatz		
Neutraler Weißmodell-Bausatz eines Wien Type M Triebwagen mit feinsten Drucken auf allen Fenstern, Kunststoffrädern und Pantograph, ohne Antrieb. KEINE Bauanleitung, aber: sie schaffen das!		
Vienna type M railcar, white model kit		
Neutral white model kit of a Vienna type M railcar, with fine prints on all windows, plastic wheels and pantograph, without drive. NO INSTRUCTIONS: yes, YOU can do it!		
WLM-NTW-BS	€ 45,00	

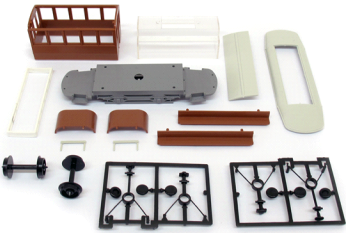
Oldtimer Neutral Beiwagen, Teilesatz		
Teilesatz: Strassenbahn, ohne Vorbild, ohne Antrieb, M 1:87, Spur H0, Kunststoffachsen, unlackiert, unbedruckt. KEINE Bauanleitung, aber: Sie schaffen das!		
Vintage neutral trailer parts kit		
Parts set: Tram, without model, without drive, scale 1:87, gauge H0, plastic axles, unpainted, NO INSTRUCTIONS: yes, YOU can do it!		
OLD-NBW-BS	€ 37,00	

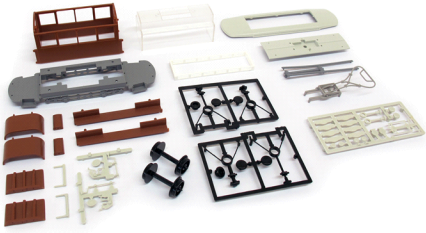
Oldtimer Neutral Triebwagen Teilesatz		
Teilesatz: Strassenbahn, ohne Vorbild, ohne Antrieb, M 1:87, Spur H0, Kunststoffachsen, unlackiert, unbedruckt. KEINE Bauanleitung, aber: Sie schaffen das!		
Vintage neutral railcar parts kit		
Parts set: Tram, without model, without drive, scale 1:87, gauge H0, plastic axles, unpainted, NO INSTRUCTIONS: yes, YOU can do it!		
OLD-NTW-BS	€ 37,00	

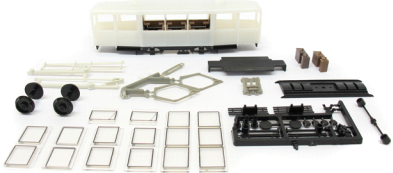
KSW Triebwagen, Weißmodell, Bausatz, Standmodell		
Neutraler Weißmodell-Bausatz eines KSW Triebwagen mit feinsten Drucken auf allen Fenstern, Kunststoffrädern und zwei unterschiedlichen Pantografen, ohne Antrieb. KEINE Bauanleitung, aber: Sie schaffen das!		
KSW railcar, white model kit, without drive		
Neutral white model kit of a KSW railcar, with fine prints on all windows, plastic wheels and two different pantographs, without drive. NO INSTRUCTIONS: yes, YOU can do it!		
KSW-NTW-BS	€ 45,00	

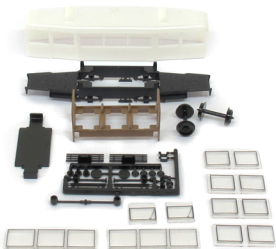
KSW Beiwagen, Weißmodell, Bausatz, Standmodell		
Neutraler Weißmodell-Teilesatz eines KSW Beiwagens mit feinsten Drucken auf allen Fenstern und Kunststoffrädern, ohne Antrieb. KEINE Bauanleitung, aber: Sie schaffen das!		
KSW trailer, white model kit, without drive		
Neutral white model kit of a KSW trailer, with fine prints on all windows, plastic wheels and two different pantographs, without drive. NO INSTRUCTIONS: yes, YOU can do it!		
KSW-NBW-BS	€ 45,00	

Komplette Teilesätze / Complete Sets

Wien Beiwagen c1, neutral, Weißmodell Teilesatz	
Teilesatz: Straßenbahn, Österreich, Wien, M1:87, Spur H0, Länge (LÜP) ca.165mm, Kunststoffradsätze, bedruckte Fenster. Umfangreiche Decal-Sets mit Wappen, Linien und Fahrziel-Aufkleber verfügbar! unbedruckt, KEINE Bauanleitung, aber: sie schaffen das!	
Vienna type c1, neutral, white model parts kit	
<i>Parts kit: Tram, Austria, Vienna, M1: 87, gauge H0, length (LÜP) ca.165mm, plastic wheel sets, printed windows. Extensive decal sets with coat of arms, lines and destination stickers available! unpainted, NO INSTRUCTIONS, : yes, YOU can do it!</i>	
WC1-NBW-BS	€ 73,00



Wien Triebwagen C1, neutral, Weißmodell Teilesatz	
Teilesatz: Straßenbahn, Österreich, Wien, M1:87, Spur H0, Länge (LÜP) ca.165mm, Metallradsätze, bedruckte Fenster, vorgefertigte Inneneinrichtung. Umfangreiche Decal-Sets mit Wappen, Linien und Fahrziel-Aufkleber verfügbar! unbedruckt, KEINE Bauanleitung, aber: sie schaffen das!	
Vienna type C1 railcar, neutral, white model parts kit	
<i>Parts kit: Tram, Austria, Vienna, M1: 87, gauge H0, length (LÜP) ca.165mm, metall wheel sets, printed windows, pre-assembly interior. Extensive decal sets with coat of arms, lines and destination stickers available! unpainted, NO INSTRUCTIONS, : yes, YOU can do it!</i>	
WC1-NTW-BS	€ 85,00

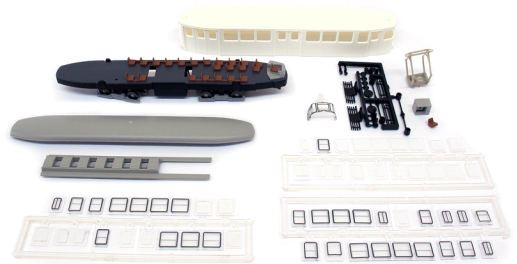

Wien Beiwagen c2, neutral, Weißmodell Teilesatz	
Teilesatz: Straßenbahn, Österreich, Wien, M 1:87, Spur H0, Länge (LÜP) ca.165 mm, Kunststoffradsätze, bedruckte Fenster. Umfangreiche Decal-Sets mit Wappen, Linien und Fahrziel-Aufkleber verfügbar! Unbedruckt, KEINE Bauanleitung, aber: Sie schaffen das!	
Vienna type c2, neutral, white model parts kit	
<i>Parts kit: Tram, Austria, Vienna, M 1:87, gauge H0, length (LÜP) ca.165 mm, plastic wheel sets, printed windows. Extensive decal sets with coat of arms, lines and destination stickers available! Unpainted, NO INSTRUCTIONS, : yes, YOU can do it!</i>	
WC2-NBW-BS	€ 73,00

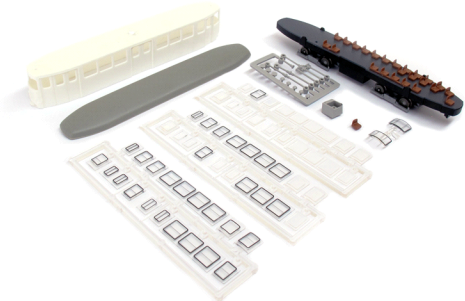

Kontrollmaß 150mm

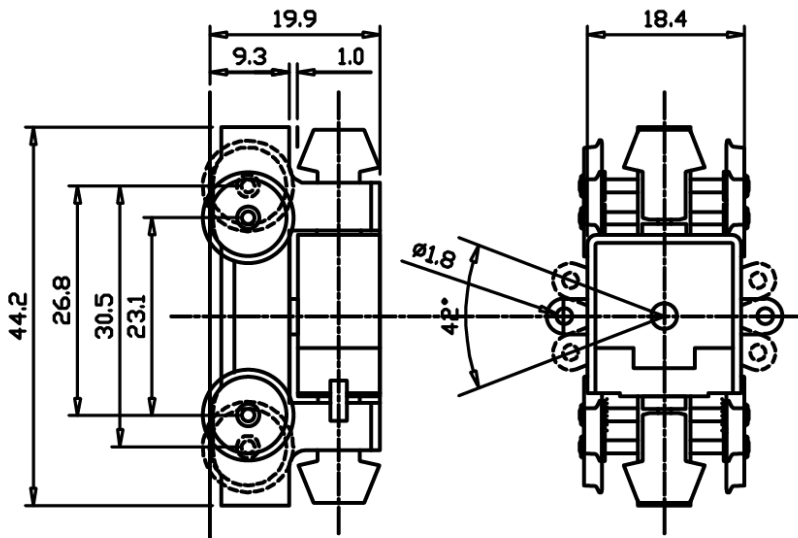

A = Achsabstand 23.1
B = Achsabstand 30.5

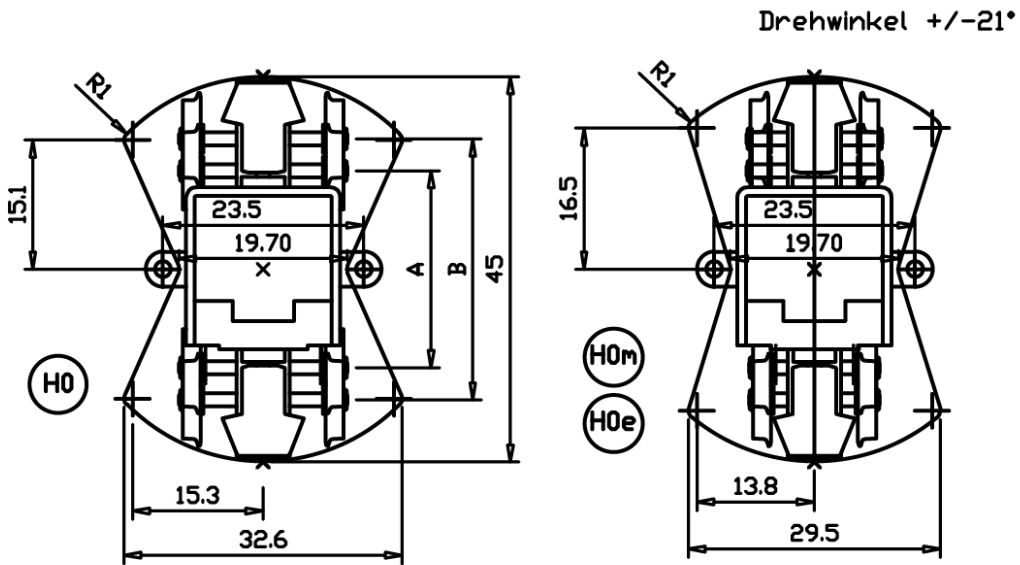

Kontrollmaß 175mm

ANT-VAR-H0x-xx-DG - 23,1/26,8/30,5 mm

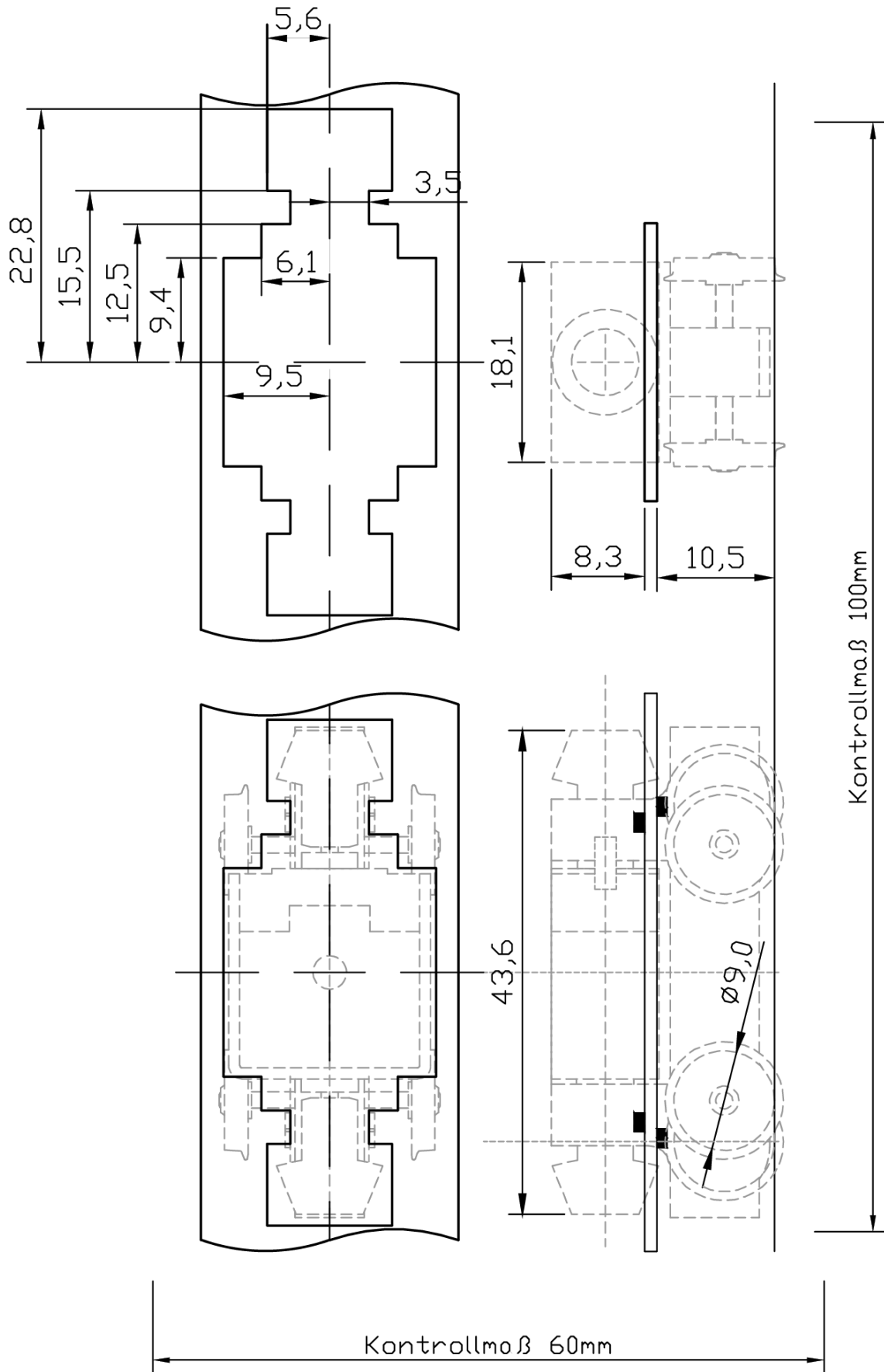

ANT-VAR-H0x-xx – 23,1/26,8/30,5 mm



HALLING MODELLE

Straßenbahn - Eisenbahn - Schmalspurbahn - Antriebe

Kontakt / *Contact*

LEOPOLD HALLING GmbH. / FERRO-TRAIN Vertriebs-GmbH.

Leopoldgasse 15-17, 1230 Wien, Österreich

Mo.-Fr. 08:00-12:00 - Abholung reservierter Ware bis 16:00 und nach Vereinbarung)

E-Mail: office@halling.at

Tel.: (+43) (1) 604 31 22- www.ferro-train.com - www.halling.at



HALLING MODELLE

Straßenbahn - Eisenbahn - Schmalspurbahn - Antriebe

Weitere Modelle

We also offer

H0 / Normalspurfahrzeuge: Überwiegend Handarbeits-Messingmodelle der Epochen I bis V, unter anderem Modelle des Dampflok-Oldtimers „Licaon“, Erztransporter der steirischen Erzbergbahn, österreichische Spantenwagen, Güterwagen aller Epochen.

H0 / standard gauge vehicles: Mostly handcrafted brass models of the epochs I to V, including models of the steam locomotive classic "Licaon", ore transporter the Styrian Erzbergbahn, Austrian railcars and freight cars of all eras.

H0e / Schmalspurfahrzeuge: überwiegend in Spritzgusstechnik gefertigte Modelle wie zB. das Zugpferd, Reihe 2095, aber auch auch die Altbaulok 2093 und der Triebwagen der Reihe 5090. Die Modelle der Mariazellerbahn, die Reihe Mh und spätere 1099 mit Altbaukasten sind Kleinserienfertigung. Wir bieten zahlreiche Personen-, Aussichts- und Buffetwagen in Kleinserien. Die vierachsigen „Krimmler“-Waggons und klassischen Vierachser (ÖBB 3200), wie sie zahlreich in Österreich verkehren, werden kontinuierlich gefertigt.

H0e / narrow gauge vehicles: predominantly injection molded models such as the Austrian classic, series 2095, but also the historic 2093 and the railcar series 5090. The models of the Mariazellerbahn, such as the steam lokos series Mh and later old electric 1099 are small series production. We also offer passenger, observation and buffet cars in small series. The four-axle "Krimmler" railcars and classic four-axle vehicles (ÖBB 3200), as they are numerous in Austria, are manufactured continuously.

H0n3z / Zahnradbahn: Weltweit einzigartig ist die voll funktionsfähige schmalspurige Zahnradbahn. Zurzeit sind Modelle für Schneeberg (Wien), Schafberg (Salzburg), Achenseebahn (Tirol), Brienz-Rothorn (Schweiz) und der Funchal/Madeira (Portugal) erhältlich. In der eigenen Spurweite H0n3z gibt es ein eigenes Schienensystem mit fix integrierter Zahnstange, verschiedenen Zahnrad-Dampfloks der Achsfolge B 1', zwei- und vierachsigen Vorstellwagen und mehrere Aussichts- und Arbeitswagen.

H0n3z / rack railway: The fully functional narrow gauge rack railway is unique in the world. Models for Schneeberg (Vienna), Schafberg (Salzburg), Achenseebahn (Tyrol), Brienz-Rothorn (Switzerland) and Funchal / Madeira (Portugal) are currently available. On the gauge of H0n3z the complete rail system with points/switches and flex tracks come with a fixed cog rack. We offer steam locos with a wheel base B 1', two- and four-axle passenger coach and several observation and trollies.

H0/H0m Nahverkehr: überwiegend in Spritzgusstechnik gefertigte, moderne und historische Fahrzeuge mit Schwerpunkt deutscher und österreichischer Betreiber wie der neue Flexity der Wiener Linien, der NGT8 Dresdens oder S- und U-Bahnmodelle aus Berlin. Die meisten Modelle sind mit oder ohne Antrieb erhältlich.

H0 / H0m public transport: predominantly injection molded modern and historic vehicles with a focus on German and Austrian operators such as the new Flexity of Wiener Linien, the NGT8 Dresden or suburban and underground models from Berlin. Most models are available with or without drive.

Z / N / H0 / O / 2 Feinste Miniaturen: Dioramen- und Anlagenzubehör mit Schwerpunkt auf H0. Gebäude (Lasercut), Fahrzeuge (Resin), Zäune, Tore, Leitern oder Grabkreuze (geätzt), Mülleimer (feinst bedruckt), und einzelne Fahrdrahtmasten werden als Fertigmodelle oder Bausätze angeboten.

Z / N / H0 / O/2 Finest Miniatures: Diorama and layout accessories with emphasis on H0. Buildings (laser cut), vehicles (Resin), fences, gates, ladders or tombs (brass etched), trash cans (finely printed), and individual catenary masts are offered as ready-made models or kits.

